

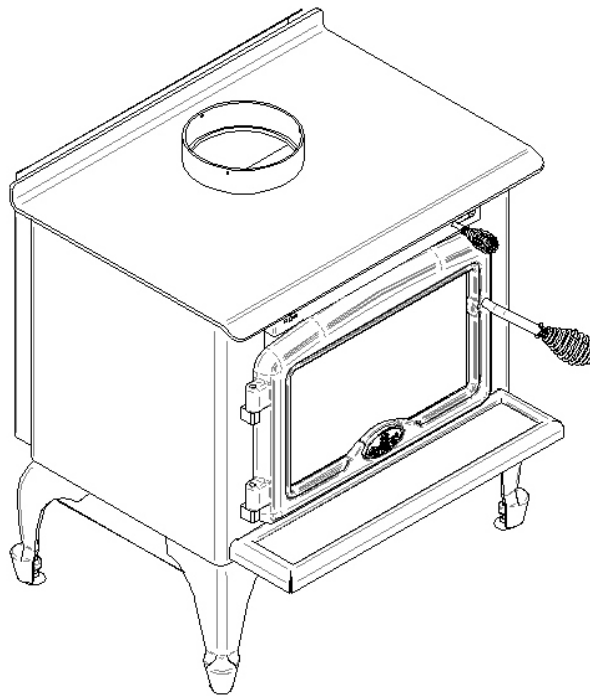

Beyond fire...

OWNER'S MANUAL

OSBURN 900 WOOD STOVE



Distributed by
My Fireplace Australia PTY Ltd
20 Auto Way
Pakenham, Victoria 3810
AUSTRALIA

Phone: 03 59 415 008 Fax: 03 59 415 975
Email: info@myfireplaceaustralia.com.au
Website: www.myfireplaceaustralia.com.au

READ AND KEEP THIS MANUAL FOR REFERENCE

45313
05-04-2012

TABLE OF CONTENTS

INTRODUCTION	3
TECHNICAL SPECIFICATIONS	4
INSTALLATION	5
POSITIONING THE STOVE	6
FLOOR PROTECTOR	6
CLEARANCES TO HEAT-SENSITIVE MATERIALS	7
REDUCED CLEARANCES USING SHIELDING	8
OPERATING AND MAINTENANCE INSTRUCTIONS.....	10
TESTING YOUR WOOD.....	11
THE FIRST FIRES.....	11
LIGHTING THE FIRE	12
HEATING	13
FAN (BLOWER) OPERATION.....	14
RELOADING	15
CREOSOTE FORMATION AND NEED FOR REMOVAL.....	15
ASH DISPOSAL.....	16
MAINTENANCE	17
GLASS.....	17
GASKETING.....	17
FIREBRICK.....	18
PAINT	19
REPLACEMENT PARTS.....	19

REGISTER YOUR WARRANTY ONLINE

To receive full warranty coverage, you will need to show evidence of the date you purchased your wood fire. Keep your sales invoice. We also recommend that you register your warranty online at

<http://osburn-australia.com/warranty-registration.aspx>

Registering your warranty online will help us track rapidly the information we need on your wood fire.

INTRODUCTION

Osburn congratulates you on your purchase and wishes to help you get maximum satisfaction from your wood stove. In the pages that follow, we will give you advice on wood heating and controlled combustion as well as technical specifications regarding installation, operation and maintenance of the model you have chosen.

The instructions pertaining to the installation of your wood stove comply with AS/NZS 4012/4013 (1999) and AS/NZS 2918:2001 standards.

Read this entire manual before you install and use your new stove. If this stove is not properly installed, a house fire may result. To reduce the risk of fire, follow the installation instructions.

Consult your local city, borough or shire council about restrictions and installations requirements in your area and the need to obtain a permit.

Keep this instruction manual for future reference.

CAUTIONS:

- HOT WHILE IN OPERATION. KEEP CHILDREN, CLOTHING AND FURNITURE AWAY. CONTACT MAY CAUSE SKIN BURNS.
- DO NOT USE CHEMICALS OR FLUIDS TO IGNITE THE FIRE.
- DO NOT LEAVE THE STOVE UNATTENDED WHEN THE DOOR IS SLIGHTLY OPENED.
- DO NOT BURN WASTES, FLAMMABLE FLUID SUCH AS GASOLINE, NAPHTHA OR MOTOR OIL.
- DO NOT CONNECT TO ANY AIR DISTRIBUTION DUCT OR SYSTEM.
- ALWAYS CLOSE THE DOOR AFTER THE IGNITION.

TECHNICAL SPECIFICATIONS

Combustible:	Wood
Maximum average heat output – hardwood (Australia):	8.9 kW
Average efficiency – hardwood (Australia):	66%
Average emissions – hardwood (Australia):	4.0 g/kg
Color :	Metallic black
Flue Spigot Diameter :	152 mm
Flue system :	Triple Skin Flue Kit
Minimum Flue Height (from floor protector):	4.6 meters
Maximum Log Length :	432 mm
Log loading :	Front to back
Overall dimensions :	W x D x H (575 x 527 x 641 mm)
Combustion Chamber :	W x D
Width x Depth :	(457 x 318 mm)
Volume :	0,034 m ³
Door Opening Dimensions:	W x H 381 x 194 mm
Weight:	79 Kg

INSTALLATION

IT IS RECOMMENDED THAT THE INSTALLATION OF YOUR OSBURN WOOD FIRE BE CARRIED OUT BY A QUALIFIED SPECIALIST INSTALLER. IF ANY ELECTRICAL WORK IS REQUIRED, IT MUST BE CARRIED OUT BY A LICENSED ELECTRICIAN.

WARNING: The instructions pertaining to the installation of your wood stove comply with the AS/NZS 2918:2001 standard. **THE APPLIANCE AND FLUE SYSTEM MUST THEREFORE BE INSTALLED IN ACCORDANCE WITH AS/NZS 2918:2001 AND THE APPROPRIATE REQUIREMENTS OF THE RELEVANT BUILDING CODE OR CODES.**

WARNING: APPLIANCES INSTALLED IN ACCORDANCE WITH THIS STANDARD SHALL COMPLY WITH THE REQUIREMENTS OF AS/NZS 4012/4013 (1999) WHERE REQUIRED BY THE REGULATORY AUTHORITY, I.E. THE APPLIANCE SHALL BE IDENTIFIABLE BY A COMPLIANCE PLATE WITH THE MARKING “TESTED TO AS/NZS 4012/4013 (1999)”.

ANY MODIFICATION OF THE APPLIANCE THAT HAS NOT BEEN APPROVED IN WRITING BY THE TESTING AUTHORITY IS CONSIDERED TO BE IN BREACH OF THE APPROVAL GRANTED FOR COMPLIANCE WITH AS/NZS 4012/4013 (1999).

CAUTION:

- MIXING OF APPLIANCE OR FLUE SYSTEM COMPONENTS FROM DIFFERENT SOURCES OR MODIFYING THE DIMENSIONAL SPECIFICATION OF COMPONENTS MAY RESULT IN HAZARDOUS CONDITIONS. WHERE SUCH ACTION IS CONSIDERED, THE MANUFACTURER SHOULD BE CONSULTED IN THE FIRST INSTANCE.
- DO NOT CONNECT TO ANY AIR DISTRIBUTION DUCT OR SYSTEM.
- CRACKED AND BROKEN COMPONENTS, e.g. GLASS PANELS OR CERAMIC TILES, MAY RENDER THIS INSTALLATION UNSAFE.
- USE SMOKE DETECTORS IN THE ROOM WHERE YOUR STOVE IS INSTALLED.
- A SOURCE OF FRESH AIR INTO THE ROOM OR SPACE HEATED SHALL BE PROVIDED WHEN REQUIRED.
- IF THIS STOVE IS NOT PROPERLY INSTALLED, A HOUSE FIRE MAY RESULT. TO REDUCE THE RISK OF FIRE, FOLLOW THE INSTALLATION INSTRUCTIONS.
- CONSULT YOUR CITY, BOROUGH OR SHIRE COUNCIL ABOUT RESTRICTIONS AND INSTALLATIONS REQUIREMENTS IN YOUR AREA.
- KEEP FURNITURE AND DRAPES WELL AWAY FROM THE STOVE.
- NEVER USE GASOLINE, GASOLINE-TYPE LANTERN FUEL, KEROSENE, CHARCOAL LIGHTER FLUID, OR SIMILAR LIQUIDS TO START OR "FRESHEN UP" A FIRE. KEEP ALL SUCH LIQUIDS WELL AWAY FROM THE STOVE.
- IN THE EVENT OF A CHIMNEY FIRE, PUSH THE AIR CONTROL FULL CLOSED TO DEPRIVE THE FIRE OF OXYGEN. CALL THE FIRE DEPARTMENT.

POSITIONING THE STOVE

It is very important to position the wood stove as close as possible to the chimney, and in an area that will favour the most efficient heat distribution possible throughout the house. The stove must therefore be installed in the room where the most time is spent, and in the most spacious room possible. Recall that wood stoves produce radiating heat, the heat we feel when we are close to a wood stove. A wood stove also functions by convection that is through the displacement of hot air accelerated upwards and its replacement with cooler air.

If necessary, the hot air distribution from the stove may be facilitated by the installation of a blower.

The wood stove must not be hooked up to a hot air distribution system since an excessive accumulation of heat may occur.

A wood stove must never be installed in a hallway or near a staircase, since it may block the way in case of fire or fail to respect required clearances.

FLOOR PROTECTOR

Your wood stove should be placed on a non-combustible surface. Install a floor protection with thermal conductivity of $0.8 \text{ m}^2\text{K/W}$ per 4 mm thick.

The floor protector should project beyond the stove as follows:

Minimum Distance From the Door Opening

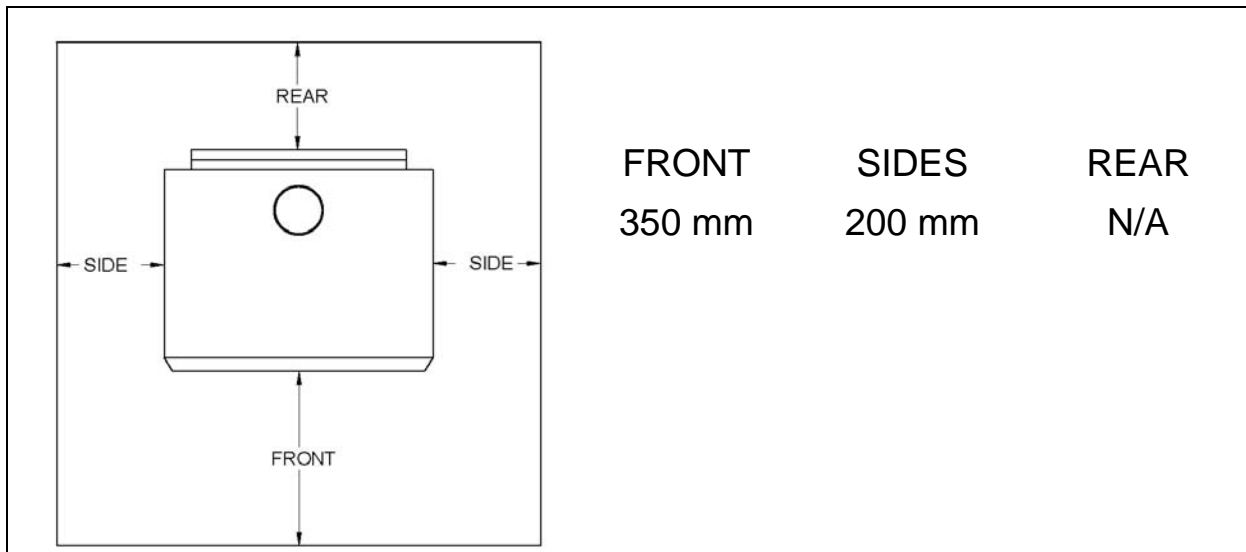

CLEARANCES TO HEAT-SENSITIVE MATERIALS

It is of outmost importance that the clearances to heat-sensitive materials be carefully maintained upon installation of the stove you have selected. Refer to the table below:

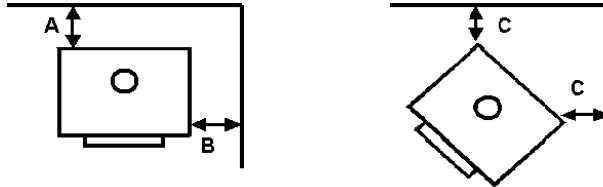

	CLEARANCES TO HEAT SENSITIVE MATERIALS		
Model	A	B	C
OSBURN 900	205 mm	400 mm	325 mm

- Floor to ceiling height must be at least 1,500 mm in all cases.
- The clearance between the flue pipe and a wall are valid only for vertical walls and for vertical flue pipe.

WHERE THE FLUE PASSES THROUGH WALLS, CEILINGS OR ROOFS, VENTILATED DOUBLE FLUE-PIPE CASINGS MUST BE USED AROUND THE FLUE PIPE, ALONG WITH CEILING PLATES AS SPECIFIED IN AS/NZS 2918:2001.

REDUCED CLEARANCES USING SHIELDING

You may decrease the minimum clearances to heat-sensitive materials by installing heat radiation shields between the walls or the ceiling and the stove. These heat radiation shields must be installed permanently, and must be made of a heat-resistant or heat-tolerant material.

An air gap must separate the heat shield from any heat-sensitive surface. Furthermore, the heat shield shall extend in all directions beyond the boundaries of the appliance surface by a distance of not less than 450 mm. **Exceptions may apply. Refer to AS/NZS 2918:2001.**

Following the installation of such heat radiation shields, the minimum clearances to heat-sensitive materials may be reduced by applying the clearances factor in the table below:

CONSTRUCTIONS AND CLEARANCES FACTORS FOR APPLIANCES HEAT SHIELDS WHICH ARE WITHIN 45° OF THE VERTICAL

HEAT SHIELD CONSTRUCTIONS	Minimum air gap dimensions (mm)	Clearances factor
Single layer of continuous material	12	0.40
Single layer of continuous material	25	0.30
Two spaced layers of continuous material	12+12	0.20

NOTES:

- 1- Masonry may be used as a heat shield material.
- 2- Where heat shields are used to reduce appliance clearance dimensions, additional flue shielding may also be required. Refer to AS/NZS 2918:2001.
- 3- Non standard installations – Refer to AS/NZS 2918:2001 for guidance.

FLUE TERMINATION REQUIREMENTS

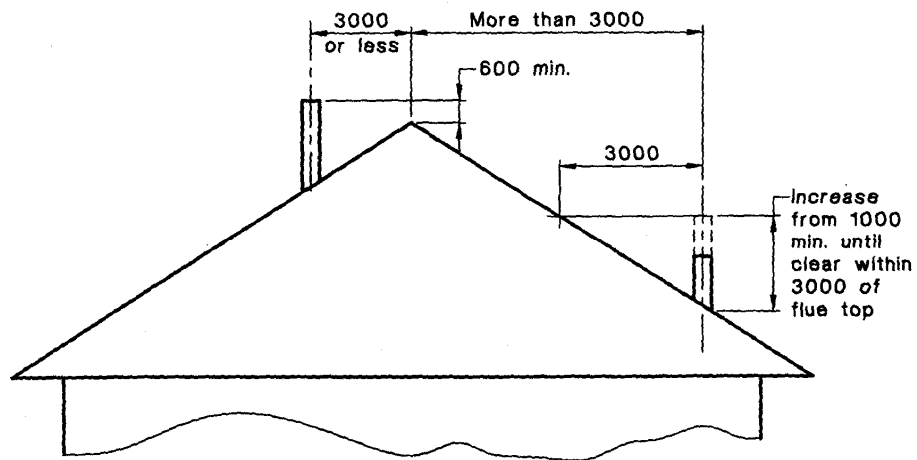
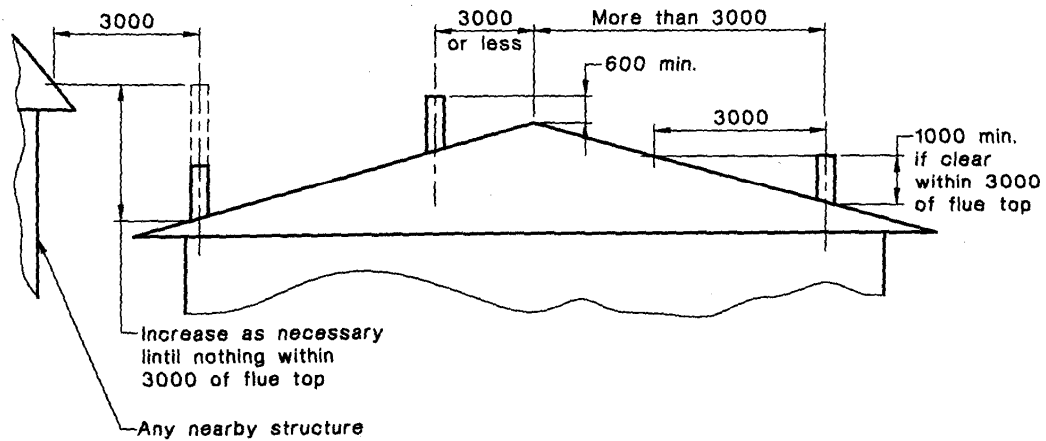

OPERATING AND MAINTENANCE INSTRUCTIONS

Keep these instructions for future reference.

WARNING:

- ANY MODIFICATION OF THE APPLIANCE THAT HAS NOT BEEN APPROVED IN WRITING BY THE TESTING AUTHORITY IS CONSIDERED AS BREACHING AS/NZS 4012/4013 (1999).
- DO NOT USE FLAMMABLE LIQUIDS OR AEROSOLS TO START OR REKINDLE THE FIRE.
- DO NOT USE FLAMMABLE LIQUIDS OR AEROSOLS IN THE VICINITY OF THIS APPLIANCE WHEN IT IS OPERATING.
- DO NOT STORE FUEL WITHIN HEATER INSTALLATION CLEARANCES.
- OPEN AIR CONTROL (AND DAMPER WHEN FITTED) BEFORE OPENING FIRING DOOR.
- THIS STOVE IS NOT DESIGNED TO BE USED WITH THE DOOR OPEN. THE DOOR MAY BE OPEN ONLY DURING LIGHTING PROCEDURES. NEVER LEAVE THE STOVE UNATTENDED WHEN THE DOOR IS OPEN.
- HOT WHILE IN OPERATION, KEEP CHILDREN, CLOTHING AND FURNITURE AWAY. CONTACT MAY CAUSE SKIN BURNS. **WEAR GLOVES TO OPERATE YOUR STOVE.**

CAUTION

- THIS APPLIANCE SHOULD BE MAINTAINED AND OPERATED AT ALL TIMES IN ACCORDANCE WITH THESE INSTRUCTIONS.
- THE USE OF SOME TYPES OF PRESERVATIVE-TREATED WOOD AS A FUEL CAN BE HAZARDOUS.

Your stove was designed to burn wood only; no other material should be burnt. Waste and other flammable materials should not be burnt in your wood stove.

IT IS EXTREMELY IMPORTANT THAT YOU USE DRY WOOD ONLY IN YOUR WOOD STOVE. The wood must have dried for 9 to 15 months, such that the moisture content below 20%. It is very important to keep in mind that even if the wood has been cut one, two or even more years, it is not necessarily dry.

Many problems related to the operation of a wood stove are caused by the fact that the wood used is too damp or has dried in poor conditions. These problems can be:

- problems lighting the fire
- creosote build-up causing flue fires
- low energy yield
- blackened windows
- incomplete log combustion

Smaller pieces of wood will dry faster. All logs exceeding 150 mm in diameter should be split. The wood should not be stored directly on the ground. Air should circulate through the cord. A 20 to 30 mm air gap should be left between each row of logs, which should be placed in the sunniest location possible. The upper layer of wood should be protected from the element but not the sides.

TESTING YOUR WOOD

When the stove is thoroughly warmed, place one piece of split wood (about 130 mm in diameter) on the bed of red embers.

Keep the air control full open by pulling on it and close the door. If ignition of the piece is accomplished within 90 seconds from the time it was placed in the stove, your wood is correctly dried. If ignition takes longer, your wood is damp.

If your wood hisses and water or vapour escapes at the ends of the piece, your wood is soaked or freshly cut. Do not use this wood in your stove. Large amounts of creosote could be deposited in your flue system, creating potential conditions for a flue fire.

THE FIRST FIRES

The fresh paint on your stove needs to be cured to preserve its quality. Once the fuel charge is properly ignited, only burn small fires in your stove for the first four hours of operation. Never open the air control more than necessary to achieve a medium burn rate.

Make sure that there is enough air circulation while curing the stove. The odours could be smelled during the 3 or 4 first fires. Never start your stove outside. You will not be able to see if you are over heating. **The smoke resulting from the paint curing process is not toxic.**

LIGHTING THE FIRE

After making sure that the stove's air intake control is fully open (completely moved to the right), place several crumpled sheets of paper in the center of the combustion chamber. Place 8 to 10 pieces of small dry kindling wood over the paper in the form of a tent. You may also place a few pieces of heating wood, but choose the smaller ones. No chemical product should be used to light the fire. Before igniting the paper and kindling wood, it is recommended that you warm up the flue. This is done in order to avoid back draught problems often due to negative pressure in the house. If such is the case, open a window slightly near the stove and twist together a few sheets of newspaper into a torch. Light up this paper torch and hold it as close as possible to the mouth of the pipe inside the combustion chamber to warm up the flue. Once the updraught movement is initiated, you are ready to ignite the stove by lighting the paper and kindling wood inside the combustion chamber. We suggest that you to leave the door slightly opened (20 mm) for a few minutes, **under supervision**, in order to allow for good combustion. After this time, you must close the door and start adding bigger pieces of wood. **The wood should be positioned in a north/south fashion, that is, from the front to the back of the firebox.** Progressively adjust the air control to obtain the desired temperature.

Use the following guidelines to adjust the air intake control to the desired burn rate:

Burn Rate	Air Control Settings
Low	Move Control against the L.H. side.
Medium Low	Move Control right by 1.3 cm from low position.
Medium High	Move Control right by 2.6 cm from low position.
High	Move Control against the R.H. side

Closing the air control down too soon will lower combustion efficiency, and may result in creosote build-up in the chimney (which could lead to a future chimney fire).

CAUTION: THE ADJUSTMENT RANGE SHOULD NOT BE ALTERED FOR INCREASED FIRING FOR ANY REASON.

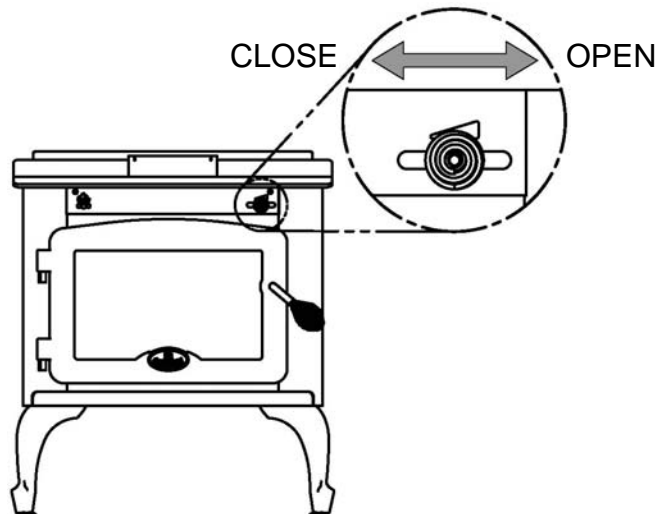

Air Intake Control

HEATING

Controlled combustion is the most efficient technique for wood heating because it enables you to select the type of combustion you want for each given situation. Always load the logs perpendicular to the door opening (front to back). The wood will burn slowly if the wood stove air intake control is adjusted to reduce the oxygen supply in the combustion chamber to a minimum. On the other hand, wood will burn quickly if the air control is adjusted to admit a larger quantity of oxygen in the combustion chamber. The air intake control on your stove is very simple. If you pulled out completely towards you, it is fully open. If you push it until it stops, the combustion air is reduced to a minimum. Your OSBURN stove may burn differently according to the species of wood used, its moisture content, the size and density of the pieces, the length of the flue, the altitude, and outside temperature.

WARNINGS

- NEVER OVERFIRE YOUR STOVE. IF ANY PART OF THE STOVE STARTS TO GLOW RED, OVER FIRING IS HAPPENING. READJUST THE AIR INTAKE CONTROL AT A LOWER SETTING.
- NEVER LOAD YOUR STOVE UP TO THE BAFFLE. ALWAYS LEAVE 5 TO 10 CENTIMETERS TO ALLOW PROPER COMBUSTION THROUGH SECONDARY AIR OPENINGS (NEVER PUT WOOD ABOVE THE FIREBRICK LINING ON THE FIREBOX). THIS WILL ALSO PREVENT OVERFIRING OF YOUR STOVE.
- THE INSTALLATION OF A LOG CRADLE IS NOT RECOMMENDED IN YOUR OSBURN WOOD STOVE.
- SHOULD THERE BE A SOOT OR CREOSOTE FIRE IN YOUR FLUE SYSTEM, CLOSE THE AIR CONTROL COMPLETELY. IMMEDIATELY CALL THE FIRE DEPARTMENT.

FAN (BLOWER) OPERATION

A fan is fitted at the back of your Osburn 900 wood stove. This greatly improves heat distribution into the room. By forcing hot air toward the front, the fan enables you to extend the radiation and convection power of your stove.

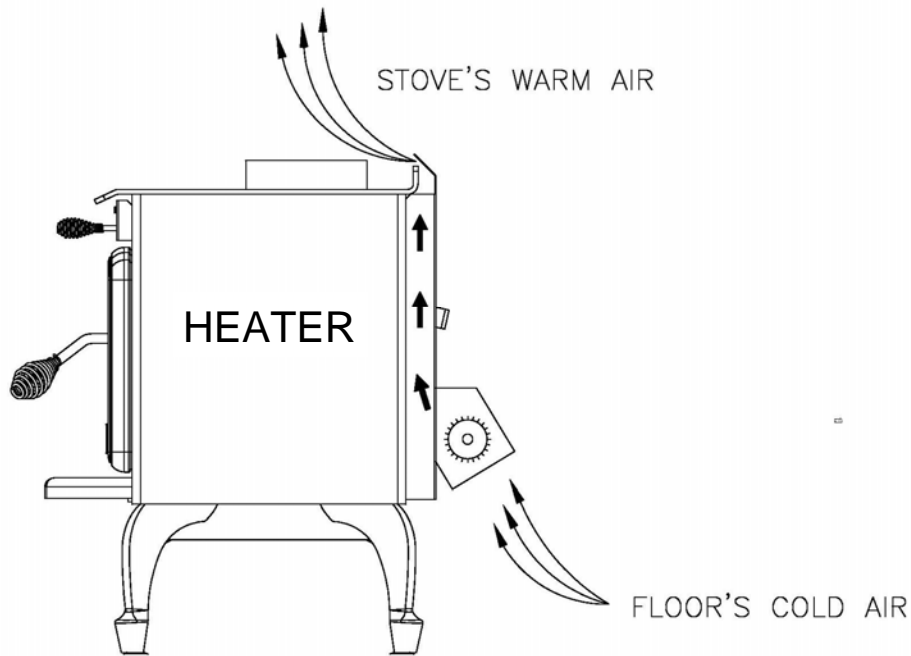

Allow the stove to reach operating temperature (approximately one hour), before turning the fan on. If the fan is turned on too quickly, the increased airflow may cool the firebox and affect the start-up combustion efficiency. The fan is equipped with a variable speed control that may be used to vary the fan's airflow based on user preferences.

CAUTION: ENSURE THAT THE FAN'S POWER CORD IS NOT IN CONTACT WITH ANY SURFACE OF THE STOVE TO PREVENT ELECTRICAL SHOCK OR FIRE DAMAGE. DO NOT RUN THE POWER CORD BENEATH THE STOVE.

RELOADING

Once you have obtained a good bed of embers, you should reload the unit. In order to do so, open the air control to its maximum for approximately 15 seconds prior to opening the stove door. Then, proceed by opening the door very slowly; open it by 20 to 40 mm for 10 to 15 seconds before opening it completely. This procedure will increase the draught and thus eliminate the smoke which is stagnant in a state of slow combustion in the stove. Then bring the red embers to the front of the stove and reload the unit. **Depending on the type of wood you burn and the strength of the draught in your flue, you may have to leave the air control open to its maximum for more than 15 seconds to avoid smoke spillage before you reload the stove.**

It is important to note that wood combustion consumes ambient oxygen in the room. In the case of negative pressure, it is a good idea to allow fresh air in the room by opening a window slightly.

CREOSOTE FORMATION AND NEED FOR REMOVAL

When wood is burnt slowly, it produces tar and other organic vapours, which combine with expelled moisture to form creosote. The creosote vapours condense in the relatively cool flue of a slow-burning fire. As a result, creosote residue accumulates on the flue system. When ignited, this creosote makes an extremely hot fire. When burning wood, the flue system should be inspected at least once every two months during the heating season to determine if a creosote build-up has occurred.

PREVENTING CREOSOTE BUILD UP

- Always burn dry wood. This allows clean burns and higher flue temperatures, therefore less creosote deposit.
- Leave the air control full open for about 10 minutes after reloading the stove to bring it back to proper operating temperatures. The secondary combustion can only take place if the firebox is hot enough.
- Always check for creosote deposit once every two months and have your flue system cleaned at least once a year.

ASH DISPOSAL

Ashes should be removed from the stove every few days or when ashes get to 2 to 3 inches deep. Always empty the stove when it is cold, such as in the morning.

Always dispose of ashes in a metal container with a tight fitting lid. Place this container on a non combustible floor or on the ground, well away from all heat-sensitive materials, pending final disposal. If the ashes are disposed of by burial in soil or otherwise locally dispersed, they should be retained in the close container until all cinders have thoroughly cooled.

CAUTIONS:

- ASHES COULD CONTAIN HOT EMBERS EVEN AFTER TWO DAYS WITHOUT OPERATING THE STOVE.
- WEAR GLOVES TO PREVENT INJURY.

MAINTENANCE

Your Osburn stove is a high efficiency stove and therefore requires little maintenance. It is important to perform a visual inspection of the stove every time it is emptied, in order to insure that no part has been damaged, in which case repairs must be performed immediately.

GLASS

- Inspect the glass regularly in order to detect any cracks. If you spot one, turn the stove off immediately. Do not abuse the glass door by striking or slamming shut. Do not use the stove if the glass is broken.
- If the glass on your stove breaks, replace only with a glass supplied by your Osburn dealer.
- To replace the glass, remove the screws retaining the glass mouldings inside the door. Remove the mouldings and replace the damaged piece with a new one. Perform the procedure backwards after replacing. When replacing the glass, you should change the glass gasket to make sure you keep it sealed.
- Never wash the glass with a product that may scratch. Use a specialized product, available in the stores where wood stoves are sold. Only wash when the stove is cold.

GASKETING

It is recommended that you change the door gasket (which makes your stove door air tight) once a year, in order to insure good control over the combustion, maximum efficiency, and security. To change the door gasket, simply remove the damaged one. Carefully clean the available gasket groove, apply a high temperature silicone (tested for 300°C or higher) sold for this purpose, and install the new gasket. **AVOID LIQUID GLUE TO FIX THE GASKET.** You may light up your stove again approximately 24 hours after having completed this operation.

WARNING:

- NEVER OPERATE THE STOVE WITHOUT A GASKET OR WITH A BROKEN ONE. DAMAGE TO THE STOVE OR EVEN HOUSE FIRE MAY RESULT

FIREBRICK

The firebrick in your stove does not need to be replaced if small cracks appear on the firebrick. However, should the firebrick start to disintegrate such that some parts of the firebox become directly exposed to the fire, you must immediately replace the firebrick. Failure to replace the firebrick will cause your stove to wear out prematurely.

ITEM	PART #	DESCRIPTION	QTY
1	29020	Refractory brick 32 mm x 114 mm x 229 mm	12
2	PL36055	Refractory brick 32 mm x 114 mm x 229 mm (CUT)	2
3	29011	Refractory brick 32 mm x 102 mm x 229 mm	2
4	PL36027	Refractory brick 32 mm x 76 mm x 229 mm	2

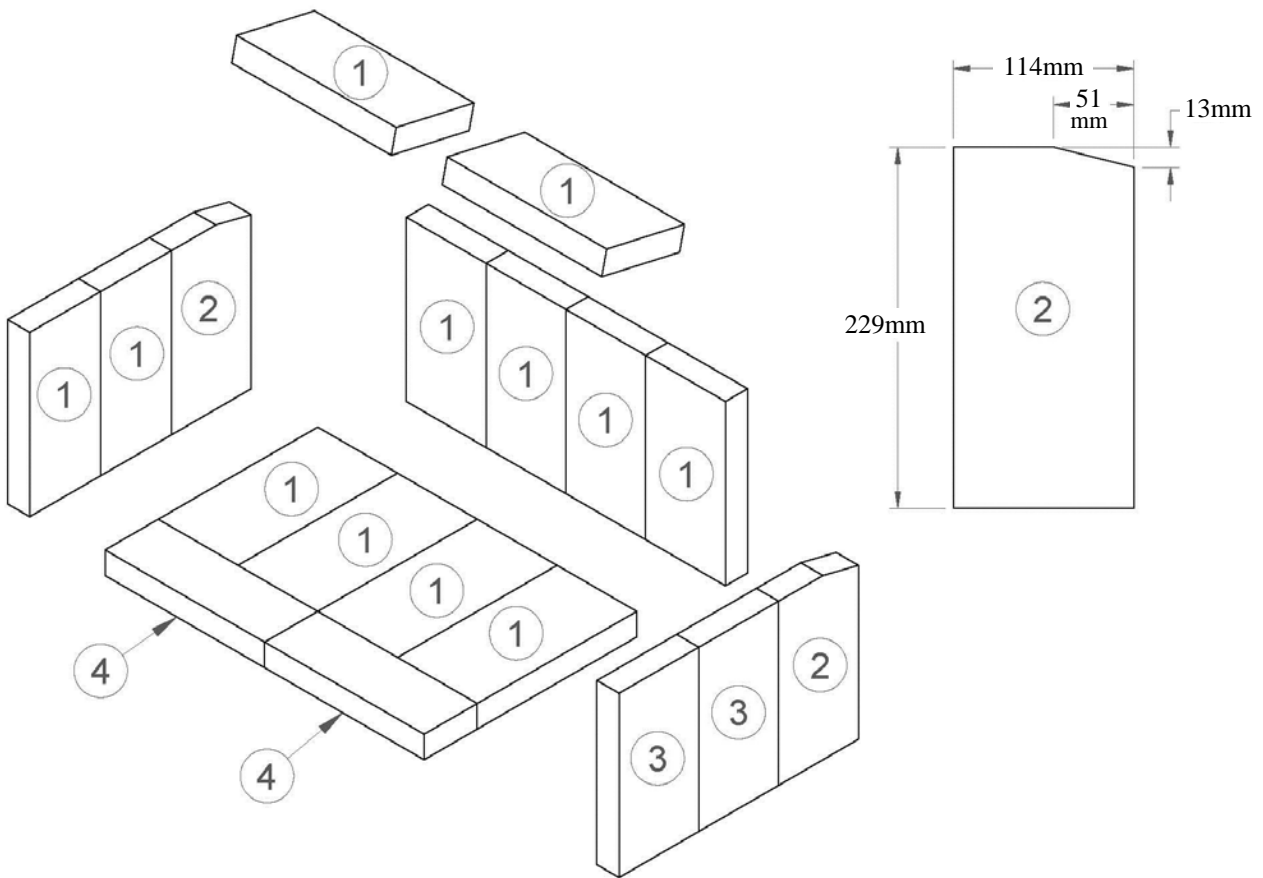

PAINT

Only clean your stove with a dry soft cloth that will not harm the paint finish.

If the paint becomes scratched or damaged, it is possible to give your wood stove a brand new look, by repainting it with a 650°C heat resistant paint. For this purpose, simply scrub the surface to be repainted with fine sand paper, clean it properly, and apply thin coats (2) of paint successively. Refer to page 19 of the present manual for the paint curing process.

REPLACEMENT PARTS

The table below presents a listing of the main replaceable components on your stove. Those components can be purchased via your OSBURN dealer.

PART #	DESCRIPTION	QTY Per stove
AC07868	<i>Black coil handle 13 mm</i>	1
AC06200	<i>Black gasket and silicone kit 6 mm x 13 mm x 279 mm</i>	1
AC07900	<i>Door handle and latch kit</i>	1
SE63190	<i>Replacement glass with gasket 222 mm x 356 mm</i>	1
PL63184	<i>Glass retainer frame</i>	2
PL53585	<i>Glass retainer</i>	8
AC07866	<i>6 mm black coil handle</i>	2

Manufactured by:
STOVE BUILDER INTERNATIONAL INC.
250, de Copenhague, Saint-Augustin-de-Desmaures (Quebec), Canada G3A 2H3
Tel: (418) 878-3040

www.osburn-australia.com

Distributed by:
My Fireplace Australia PTY Ltd