

# INSTALLATION AND OPERATION MANUAL

## MATRIX INBUILT (OB02023 Model)

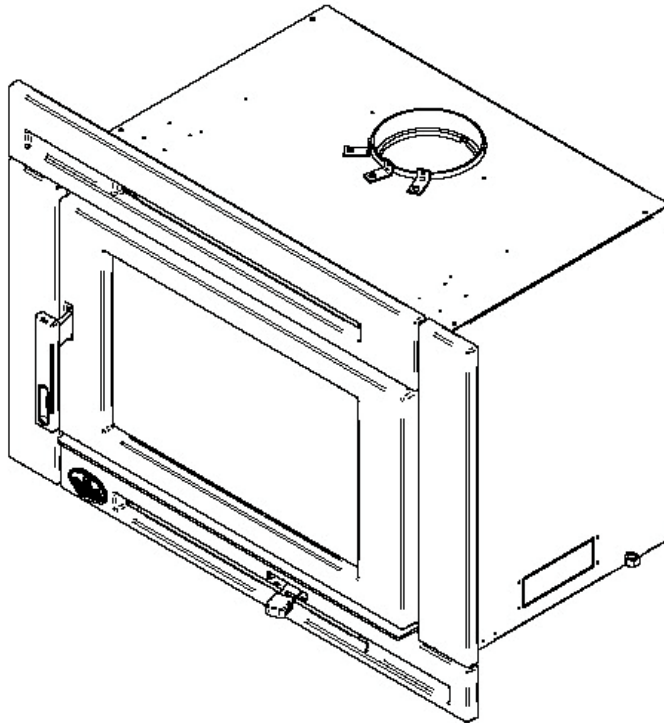

BEYOND  
fire



YOUR OSBURN MATRIX INBUILT HAS BEEN TESTED WITH OUR ORIGINAL OSBURN MATRIX ZERO CLEARANCE KIT. THE INSTALLATION OF ANY OTHER ZERO CLEARANCE KIT WILL VOID YOUR WARRANTY.

Distributed by  
My Fireplace Australia PTY Ltd  
20 Auto Way  
Pakenham, Victoria 3810  
AUSTRALIA

Phone: 03 59 415 008 Fax: 03 59 415 975  
Email: [info@myfireplaceaustralia.com.au](mailto:info@myfireplaceaustralia.com.au)  
Website: [www.myfireplaceaustralia.com.au](http://www.myfireplaceaustralia.com.au)



*This manual is available for free download on the manufacturer's web site. It is a copyrighted document. Re-sale is strictly prohibited. The manufacturer may update this manual from time to time and cannot be responsible for problems, injuries, or damages arising out of the use of information contained in any manual obtained from unauthorized sources.*

**READ AND KEEP THIS MANUAL FOR REFERENCE**

**THANK YOU FOR CHOOSING THIS WOOD INBUILT**

We want to congratulate you on your purchase and wish to help you get maximum satisfaction from your wood inbuilt. In the pages that follow, we will give you advice on wood heating and controlled combustion as well as technical specifications regarding installation, operation and maintenance of the model you have chosen.

The instructions pertaining to the installation of your wood inbuilt comply with AS/NZS 4012/4013 (1999) and AS/NZS 2918:2001 standards.

**Please read this entire manual before you install and use your new wood inbuilt. Failure to follow instructions may result in property damage, bodily injury, or even death. It is important that you follow the installations guidelines exactly.**

**Consult your local city, borough or shire council about restrictions and installations requirements in your area and the need to obtain a permit.**

**This heating unit is designed to serve as a supplementary heat source. We recommend that a primary heat source also be available in the home. The manufacturer cannot be responsible for costs associated with the use of another heating system.**

**KEEP THIS INSTRUCTION MANUAL FOR FUTURE REFERENCE.**

## Table of content

<b>PART A - OPERATION AND MAINTENANCE .....</b>	<b>6</b>
<b>1 Safety Information .....</b>	<b>6</b>
1.1 Summary of Operation and Maintenance Cautions and Warnings .....	6
<b>2 General Information.....</b>	<b>7</b>
2.1 OSBURN Matrix Specifications .....	7
2.2 Zone Heating and How to Make it Work for You .....	8
2.3 The Benefits of Low Emissions and High Efficiency.....	10
2.4 Osburn’s Commitment to You and the Environment.....	10
2.4.1 What is Your New Wood inbuilt Made Of? .....	10
<b>3 Fuel.....</b>	<b>11</b>
3.1 Materials That Should Not be Burned .....	11
3.2 How to Prepare or Buy Good Firewood .....	11
3.2.1 What is Good Firewood? .....	11
3.2.2 Tree Species .....	11
3.2.3 Log Length.....	11
3.2.4 Piece Size.....	12
3.2.5 How to Dry Firewood .....	13
3.2.6 Judging Firewood Moisture Content .....	14
3.3 Manufactured Logs.....	14
<b>4 Operating Your Wood inbuilt.....</b>	<b>15</b>
4.1 The use of a fire screen.....	15
4.2 Your First Fires .....	15
4.3 Lighting Fires.....	16
4.3.1 Conventional Fire Starting .....	16
4.3.2 The Top Down Fire .....	16
4.3.3 Two Parallel Logs.....	17
4.3.4 Using Fire Starters.....	17
4.4 Maintaining Wood fires.....	17
4.4.1 General Advice .....	17
4.4.2 Ash Removal.....	18
4.4.3 Raking Charcoal.....	18
4.4.4 Firing Each New Load Hot .....	19
4.4.5 Turning Down the Air Supply .....	19
4.5 Blower Operation .....	20
4.5.1 Building Different Fires for Different Needs .....	20

<b>5</b>	<b>Maintaining Your Wood Heating System.....</b>	<b>22</b>
5.1	Wood inbuilt Maintenance.....	22
5.1.1	Cleaning Door Glass .....	22
5.1.2	Door adjustment.....	23
5.1.3	Replacing the Door Gasket.....	24
5.1.4	Replacing the Glass Gasket and/or the Glass .....	24
5.1.5	Cleaning and Painting the Wood inbuilt .....	25
5.2	Flue and Flue Liner Maintenance .....	25
5.2.1	Why Flue System Cleaning is Necessary .....	25
5.2.2	How Often Should You Clean the Flue System? .....	26
5.2.3	Cleaning the Flue System.....	26
	<b>PART B – INSTALLATION.....</b>	<b>27</b>
<b>6</b>	<b>Pre-Installation requirements .....</b>	<b>27</b>
6.1	Masonry Fireplace .....	27
6.2	Zero-Clearance Kit .....	27
<b>7</b>	<b>Safety Information .....</b>	<b>28</b>
7.1	Summary of Installation Cautions and Warnings.....	28
7.2	Regulations Covering Wood inbuilt Installation.....	29
<b>8</b>	<b>Clearances to Heat-Sensitive Materials .....</b>	<b>30</b>
8.1	Location of the Certification Label .....	30
8.2	Positioning the Unit .....	30
8.3	Minimum Masonry Opening, Clearances to Combustibles, and Floor Protector .....	33
<b>9</b>	<b>The Flue System .....</b>	<b>35</b>
9.1	General .....	35
9.2	Suitable Flue Systems .....	35
9.3	Liner installation .....	35
9.4	Flue liner installation .....	36
9.4.1	If the flue liner does align with the wood inbuilt’s flue outlet, you have two options ...	36
9.4.2	If the flue liner does not align with the wood inbuilt’s flue outlet.....	37
9.5	Minimum Flue System Height .....	38
9.6	The Relationship Between the Flue System and the House.....	39
9.6.1	Why the Flue System Should Penetrate the Highest Heated Space.....	39
9.7	Air quality in the house.....	39

**Appendix 1: Reversing the Door Opening and Adjusting the Handle .... 40**  
**Appendix 2: Installing the Optional Fresh Air Intake Kit (AC01298) ..... 42**  
**Appendix 3: Optional Faceplate Installation ..... 43**  
**Appendix 4: Blower Installation ..... 45**  
**Appendix 5: Installing the Optional Fire Screen (AC01315) ..... 47**  
**Appendix 6: Installation of Secondary Air Tubes and Baffle ..... 48**  
**Appendix 7: Removal instructions ..... 50**  
**Appendix 8: Exploded Diagram and Parts List ..... 51**

**REGISTER YOUR WARRANTY ONLINE**

To receive full warranty coverage, you will need to show evidence of the date you purchased your wood inbuilt. Keep your sales invoice. We also recommend that you register your warranty online at

<http://www.osburn-australia.com/en/service-support/warranty-registration>

Registering your warranty online will help us track rapidly the information we need on your wood inbuilt.

## **PART A - OPERATION AND MAINTENANCE**

Please see Part B for installation instructions.

### **1 SAFETY INFORMATION**

#### **1.1 SUMMARY OF OPERATION AND MAINTENANCE CAUTIONS AND WARNINGS**

- **HOT WHILE IN OPERATION, KEEP CHILDREN, CLOTHING AND FURNITURE AWAY. CONTACT MAY CAUSE SKIN BURNS. GLOVES MAY BE NEEDED FOR WOOD INBUILT OPERATION.**
- **USING A WOOD INBUILT WITH CRACKED OR BROKEN COMPONENTS, SUCH AS GLASS OR FIREBRICKS OR BAFFLES MAY PRODUCE AN UNSAFE CONDITION AND MAY DAMAGE THE WOOD INBUILT.**
- **OPERATE ONLY WITH DOOR FULLY CLOSED OR FULLY OPEN WITH FIRE SCREEN IN PLACE. IF DOOR IS LEFT PARTLY OPEN, GAS AND FLAME MAY BE DRAWN OUT OF THE OPENING, CREATING RISKS FROM BOTH FIRE AND SMOKE.**
- **OPEN THE AIR CONTROL FULLY BEFORE OPENING FIRING DOOR.**
- **THIS WOOD INBUILT HAS BEEN TESTED FOR USE WITH AN OPEN DOOR IN CONJUNCTION WITH A FIRE SCREEN (AC01315, SOLD SEPARATELY). THE DOOR MAY BE OPEN OR FIRE SCREEN REMOVED ONLY DURING LIGHTING PROCEDURES OR RELOADING. ALWAYS CLOSE THE DOOR OR PUT BACK THE FIRE SCREEN AFTER IGNITION. DO NOT LEAVE THE WOOD INBUILT UNATTENDED WHEN THE DOOR IS OPENED WITH OR WITHOUT FIRE SCREEN.**
- **NEVER USE GASOLINE, GASOLINE-TYPE LANTERN FUEL (NAPHTHA), FUEL OIL, MOTOR OIL, KEROSENE, CHARCOAL LIGHTER FLUID, OR SIMILAR LIQUIDS OR AEROSOLS TO START OR 'FRESHEN UP' A FIRE IN THIS WOOD INBUILT. KEEP ALL SUCH LIQUIDS OR AEROSOLS WELL AWAY FROM THE WOOD INBUILT WHILE IT IS IN USE.**
- **DO NOT CONNECT TO ANY AIR DISTRIBUTION DUCT OR SYSTEM.**
- **DO NOT STORE FUEL WITHIN HEATER MINIMUM INSTALLATION CLEARANCES.**
- **BURN ONLY SEASONED NATURAL FIREWOOD.**
- **THE USE OF SOME TYPES OF PRESERVATIVE-TREATED WOOD AS A FUEL CAN BE HAZARDOUS.**
- **DO NOT BURN:**
  - **GARBAGE OF ANY KIND,**
  - **COAL OR CHARCOAL,**
  - **TREATED, PAINTED OR COATED WOOD,**
  - **PLYWOOD OR PARTICLE BOARD,**
  - **FINE PAPER, COLORED PAPER OR CARDBOARD,**
  - **SALT WATER DRIFTWOOD, OR**
  - **RAILROAD TIES.**
- **DO NOT ELEVATE THE FIRE BY USING A GRATE IN THIS WOOD INBUILT.**
- **THIS APPLIANCE SHOULD BE MAINTAINED AND OPERATED AT ALL TIMES IN ACCORDANCE WITH THESE INSTRUCTIONS.**

## 2 GENERAL INFORMATION

### 2.1 OSBURN MATRIX SPECIFICATIONS

Combustible:	Wood
Heating capacity*	195 m <sup>2</sup>
Average peak power – hardwood (Australia):	10.1 kW
Average efficiency – hardwood (Australia):	61 %
Average emissions – hardwood (Australia):	0.8 g/kg
Burn Time*	6 to 8 hours
Color :	Metallic black
Flue Spigot Diameter :	150 mm
Flue system :	Triple skin or liner
Minimum Flue Height (from floor protector):	4.6 meters
Maximum Log Length :	508 mm sideways**
Log loading :	Sideways
Firebox Volume :	0,068 m <sup>3</sup>
Weight:	215 kg
Baffle Material	C-Cast

\* Burn time and heating capacity may vary subject to location in home, flue system draft, flue system diameter, locality, heat loss factors, climate, fuels and other variables.

\*\* Sideways: through the door you see the sides of the logs.

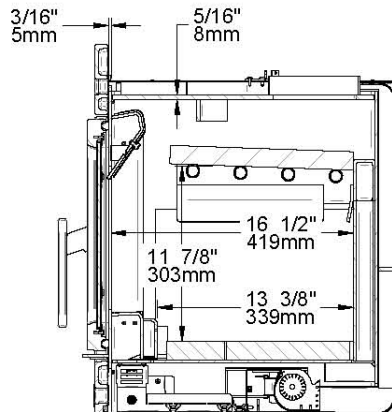
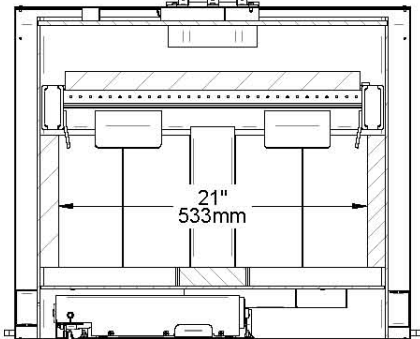
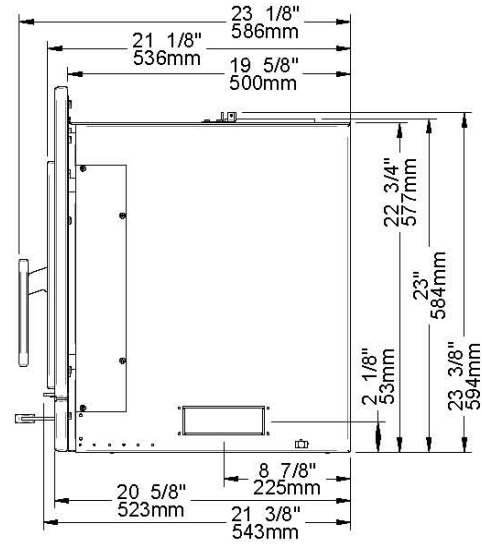
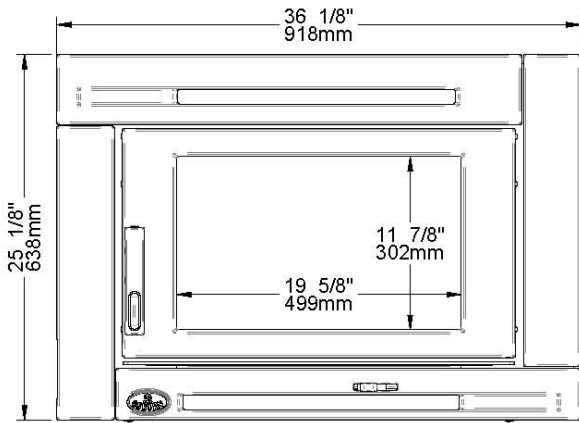
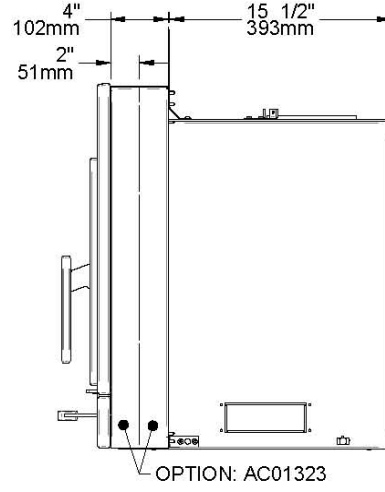
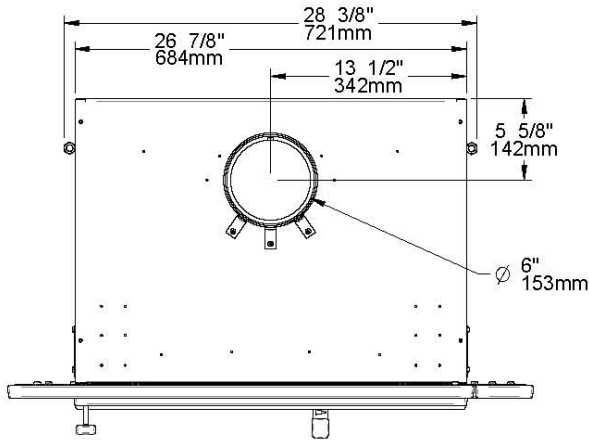



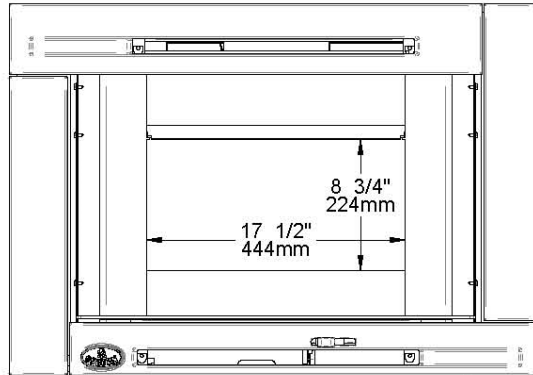

## 2.2 ZONE HEATING AND HOW TO MAKE IT WORK FOR YOU

Your new Osburn Matrix wood inbuilt is a space heater, which means it is intended to heat the area it is installed in, as well as spaces that connect to that area, although to a lower temperature. This is called zone heating and it is an increasingly popular way to heat homes or spaces within homes.

Zone heating can be used to supplement another heating system by heating a particular space within a home, such as a basement family room or an addition that lacks another heat source.

Houses of moderate size and relatively new construction can be heated with a properly sized and located wood inbuilt. Whole house zone heating works best when the inbuilt is located in the part of the house where the family spends most of its time. This is normally the main living area where the kitchen, dining and living rooms are located. By locating the inbuilt in this area, you will get the maximum benefit of the heat it produces and will achieve the highest possible heating efficiency and comfort. The space where you spend most of your time will be warmest, while bedrooms and basement (if there is one) will stay cooler. In this way, you will burn less wood than with other forms of heating.

Although the wood inbuilt may be able to heat the main living areas of your house to an adequate temperature, we strongly recommend that you also have a conventional oil, gas or electric heating system to provide backup heating.

Your success with zone heating will depend on several factors, including the correct sizing and location of the wood inbuilt, the size, layout and age of your home and your climate zone. Three-season vacation homes can usually be heated with smaller wood inbuilts than houses that are heated all winter.

## 2.3 THE BENEFITS OF LOW EMISSIONS AND HIGH EFFICIENCY

The low smoke emissions produced by the special features inside the Osburn Matrix firebox mean that your household will release up to 90 percent less smoke into the outside environment than if you used an older conventional wood inbuilt. But there is more to the emission control technologies than protecting the environment.

The smoke released from wood when it is heated contains about half of the energy content of the fuel. By burning the wood completely, your wood inbuilt releases all the heat energy from the wood instead of wasting it as smoke up the flue system. Also, the features inside the firebox allow you to reduce the air supply to control heat output, while maintaining clean and efficient flaming combustion, which boosts the efficient delivery of heat to your home.

The emission control and advanced combustion features of your wood inbuilt can only work properly if your fuel is in the correct moisture content range of 15 to 20 percent. See **Section 3** of this manual for suggestions on preparing fuelwood and judging its moisture.

## 2.4 OSBURN'S COMMITMENT TO YOU AND THE ENVIRONMENT

The Osburn team is committed to protecting the environment, so we do everything we can to use only materials in our products that will have no lasting negative impact on the environment.

### 2.4.1 WHAT IS YOUR NEW WOOD INBUILT MADE OF?

The body of your wood inbuilt, which is most of its weight, is carbon steel. Should it ever become necessary many years in the future, almost the entire wood inbuilt can be recycled into new products, thus eliminating the need to mine new materials.

The paint coating on your wood inbuilt is very thin. Its VOC content (Volatile Organic Components) is very low. VOCs can be responsible for smog, so all the paint used during the manufacturing process meets the latest air quality requirements with regards to VOC reduction or elimination.

The air tubes are stainless steel, which can also be recycled.

The C-Cast baffle is made of an aluminosilicate fibre material that is compressed with a binder to form a rigid board. C-Cast can withstand temperatures above 1 093 °C (2,000 °F.) It is not considered hazardous waste. Disposal at a landfill is recommended.

Firebrick is mainly composed of silicon dioxide, also known as silica, a product processed from a mined mineral. It is most commonly found in nature in the form of sand and clay. Disposal at a landfill is recommended.

The door and glass gaskets are fibreglass which is spun from melted sand. Black gaskets have been dipped into a solvent-free solution. Disposal at a landfill is recommended.

The door glass is a 4 mm thick ceramic material that contains no toxic chemicals. It is basically made of raw earth materials such as sand and quartz that are combined in such a way to form a glass at high temperatures. Ceramic glass will not re-melt in the same way as normal glass, so it should not be recycled with your regular household products. Disposal at a landfill is recommended.

## **3 FUEL**

### **3.1 MATERIALS THAT SHOULD NOT BE BURNED**

- **GARBAGE OF ANY KIND,**
- **COAL OR CHARCOAL,**
- **TREATED, PAINTED OR COATED WOOD,**
- **PLYWOOD OR PARTICLE BOARD,**
- **FINE PAPER, COLORED PAPER OR CARDBOARD,**
- **SALT WATER DRIFTWOOD,**
- **MANUFACTURED LOGS CONTAINING WAX OR CHEMICAL ADDITIVES,**
- **RAILROAD TIES,**
- **LIQUIDS SUCH AS KEROSENE OR DIESEL FUEL TO START A FIRE.**

### **3.2 HOW TO PREPARE OR BUY GOOD FIREWOOD**

#### **3.2.1 WHAT IS GOOD FIREWOOD?**

Good firewood has been cut to the correct length for the wood inbuilt, split to a range of sizes and stacked in the open until its moisture content is reduced to 15 to 20 per cent.

#### **3.2.2 TREE SPECIES**

The tree species the firewood is produced from is less important than its moisture content. The main difference in firewood from various tree species is the density of the wood. Hardwoods such as gums, Manuka or ironbark are denser than softwoods. Hard wood will produce long-lasting coal beds combined to more heat and longer burn cycles.

Old, leaky cast iron wood inbuilts wouldn't hold a fire overnight unless they were fed large pieces of hardwood. That is no longer true. You can successfully heat your home by using less wood and give the forest a break at the same time.

#### **3.2.3 LOG LENGTH**

Logs should be cut about 25 mm (1") shorter than the firebox so they fit in easily. Pieces that are slightly too long make loading the wood inbuilt very difficult. The most common standard length of firewood is 400 mm (16").

The pieces should be a consistent length, with a maximum of 25 mm (1") variation from piece to piece.

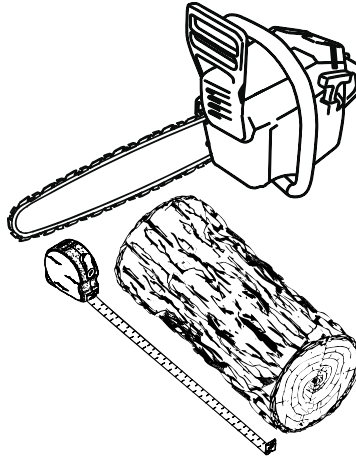

### 3.2.4 PIECE SIZE

Firewood dries more quickly when it is split. Large unsplit rounds can take years to dry enough to burn. Even when dried, unsplit logs are difficult to ignite because they don't have the sharp edges where the flames first catch. Logs as small as 75 mm (3") should be split to encourage drying.

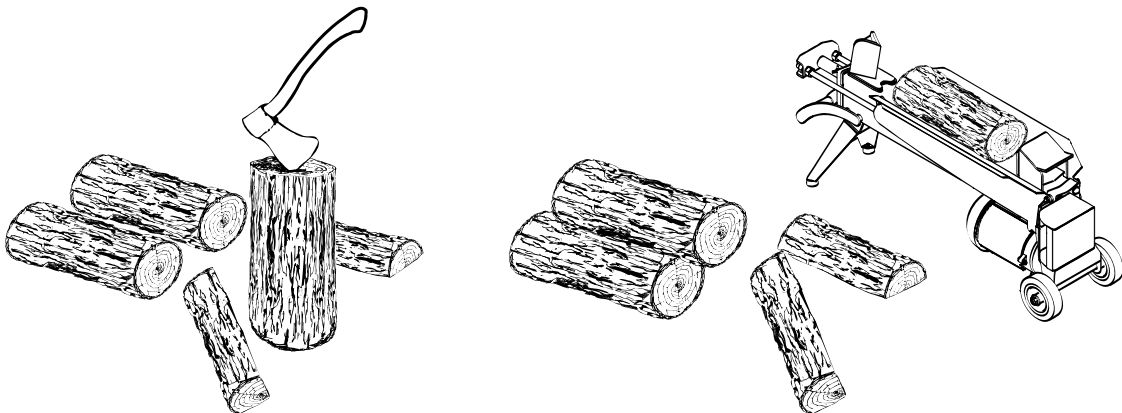

Wood should be split to a range of sizes, from about 75 mm to 150 mm (3" to 6") in cross section. Having a range of sizes makes starting and rekindling fires much easier. Often, the firewood purchased from commercial suppliers is not split finely enough for convenient stoking. It is sometimes advisable to resplit the wood before stacking to dry.

### 3.2.5 HOW TO DRY FIREWOOD

Firewood that is not dry enough to burn is the cause of most complaints about wood inbuilts. Continually burning green or unseasoned wood produces more creosote and involves lack of heat and dirty glass door. See **Section 5: Maintaining your wood heating system** for concerns about creosote.

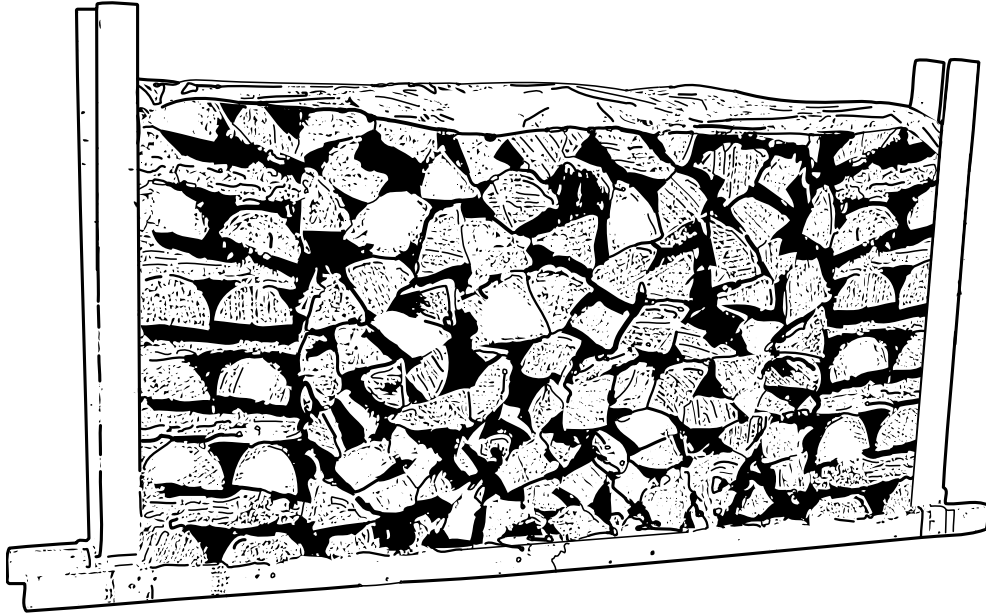

Here are some things to consider in estimating drying time:

- firewood takes a long time to dry
- firewood bought from a dealer is rarely dry enough to burn, so it is advisable to buy the wood in spring and dry it yourself
- drying happens faster in dry weather than in damp, maritime climates
- drying happens faster in warm summer weather than in winter weather
- small pieces dry more quickly than large pieces
- split pieces dry more quickly than unsplit rounds
- softwoods take less time to dry than hardwoods
- hardwoods like gums, Manuka and ironbark can take one, or even two years to dry fully, especially if the pieces are big
- firewood dries more quickly when stacked in the open where it is exposed to sun and wind; it takes much longer to dry when stacked in a wood shed
- firewood that is ready to burn has a moisture content between 15 and 20% by weight and will allow your wood inbuilt to produce its highest possible efficiency

### 3.2.6 JUDGING FIREWOOD MOISTURE CONTENT

You can find out if some firewood is dry enough to burn by using these guidelines:

- cracks form at the ends of logs as they dry
- as it dries in the sun, the wood turns from white or cream coloured to grey or yellow,
- bang two pieces of wood together; seasoned wood sounds hollow and wet wood sounds dull,
- dry wood is much lighter in weight than wet wood,
- split a piece, and if the fresh face feels warm and dry it is dry enough to burn; if it feels damp, it is too wet,
- burn a piece; wet wood hisses and sizzles in the fire and dry wood does not.

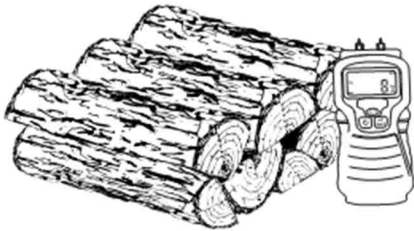

You could buy a wood moisture meter to test your firewood.

### 3.3 MANUFACTURED LOGS

Do not burn manufactured logs made of wax impregnated sawdust or logs with any chemical additives. Manufactured logs made of 100% compressed sawdust can be burned, but use caution in the number of these logs burned at one time. Start with one manufactured log and see how the wood inbuilt reacts. You can increase the number of logs burned at a time to making sure the temperature never rises higher than 246 °C (475 °F) on a magnetic thermometer for installation on wood inbuilt flue. The thermometer should be placed about 450 mm (18") above the wood inbuilt. Higher temperatures can lead to overheat and damage your wood inbuilt.

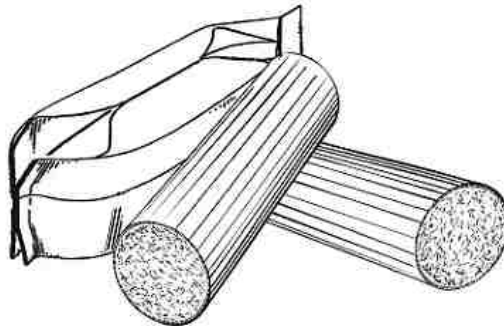

## 4 OPERATING YOUR WOOD INBUILT

- NEVER OVERFIRE YOUR WOOD INBUILT. IF ANY PART OF THE WOOD INBUILT STARTS TO GLOW RED, OVER FIRING IS HAPPENING. READJUST THE AIR INTAKE CONTROL AT A LOWER SETTING.
- NEVER LOAD YOUR WOOD INBUILT UP TO THE BAFFLE. ALWAYS LEAVE 5 TO 10 CENTIMETERS TO ALLOW PROPER COMBUSTION THROUGH SECONDARY AIR OPENINGS (NEVER PUT WOOD ABOVE THE FIREBRICK LINING ON THE FIREBOX). THIS WILL ALSO PREVENT OVERFIRING OF YOUR WOOD INBUILT.
- SHOULD THERE BE A SOOT OR CREOSOTE FIRE IN YOUR FLUE SYSTEM, CLOSE THE AIR CONTROL COMPLETELY. IMMEDIATELY CALL THE FIRE DEPARTMENT.

### 4.1 THE USE OF A FIRE SCREEN.

This wood inbuilt has been tested for use with an open door in conjunction with a fire screen (AC01315, sold separately). Make sure the fire screen is properly secured on the wood inbuilt to avoid any risk of sparks damaging your flooring. When the fire screen is in use, do not leave the wood inbuilt unattended so that you can respond promptly in the event of smoke spillage into the room. Potential causes of smoke spillage are described in **Section 9 The Flue System** of this manual. See **Appendix 5: Installing the Fire Screen (AC01315)** for installation instructions.

**OPERATING WITH THE FIRE SCREEN INCREASES POSSIBILITIES OF GENERATING CARBON MONOXIDE. CARBON MONOXIDE IS AN ODOURLESS GAS THAT IS HIGHLY TOXIC AND WHICH CAN CAUSE DEATH AT HIGH CONCENTRATION IN AIR.**

### 4.2 YOUR FIRST FIRES

Two things will happen as you burn your first few fires; the paint cures and the internal components of the wood inbuilt are conditioned.

As the paint cures, some of the chemicals vaporize. The vapors are not poisonous, but they do smell bad. Fresh paint fumes can also cause false alarms in smoke detectors. So, when you first light your wood inbuilt, be prepared by opening doors and/or windows to ventilate the house. As you burn hotter and hotter fires, more of the painted surfaces reach the curing temperature of the paint. The smell of curing paint does not disappear until you have burned one or two very hot fires.

Burn one or two small fires to begin the curing and conditioning process. Then build bigger and hotter fires until there is no longer any paint smell from the wood inbuilt. Once the paint smell disappears, your wood inbuilt is ready for serious heating.

### 4.3 LIGHTING FIRES

Each person who heats with wood develops their own favorite way to light fires. Whatever method you choose, your goal should be to get a hot fire burning quickly. A fire that starts fast produces less smoke and deposits less creosote in the flue system. Here are three popular and effective ways to start wood inbuilts.

#### 4.3.1 CONVENTIONAL FIRE STARTING

The conventional way to build a wood inbuilt is to bunch up 5 to 10 sheets of plain newspaper and place them in the firebox. Next, place 10 or so pieces of fine kindling on the newspaper. This kindling should be very thin; less than 25 mm (1"). Next, place some larger kindling pieces on the fine kindling. Open the air control fully and light the newspaper. If you have a tall, straight flue system you should be able to close the door immediately and the fire will ignite. If your flue has elbows or an outside flue system, you may need to leave the door closed but unlatched for a few minutes as the newspaper ignites and heat in the flue system produces some draft. Once the fire has ignited, close the door and leave the air control fully open.

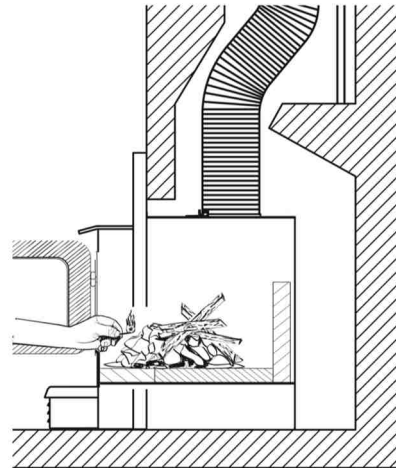

*A conventional kindling fire with paper under finely split wood.*

**DO NOT LEAVE THE WOOD INBUILT UNATTENDED WHEN THE DOOR IS SLIGHTLY OPENED DURING IGNITION. ALWAYS CLOSE THE DOOR AFTER IGNITION.**

After the kindling fire has mostly burned, you can add standard firewood pieces until you have a fire of the right size for the conditions.

#### 4.3.2 THE TOP DOWN FIRE

The top down fire starting method solves two problems with the conventional method: first, it does not collapse and smother itself as it burns; and second, it is not necessary to build up the fire gradually because the firebox is loaded before the fire is lit. A top down fire can provide up to two hours of heating or more. The top down method only works properly if the wood is well-seasoned.

Start by placing three or four full-sized split pieces of dry firewood in the firebox. Next, place 4 or 5 more finely split pieces of firewood (50 mm to 75 mm [2" to 3"] in dia.) on the base logs at right angles (log cabin style). Now place about 10 pieces of finely split kindling on the second layer at right angles.

The fire is topped with about 5 sheets of newspaper. You can just bunch them up and stuff them in between the kindling and the underside of the baffle. Or you can make newspaper knots by rolling up single sheets corner to corner and tying a knot in them. The advantage of knots is that they don't roll off the fire as they burn. Light the newspaper and watch as the fire burns from top to bottom.



### 4.3.3 TWO PARALLEL LOGS

Place two spit logs in the firebox. Place a few sheets of twisted newspaper between the logs. Now place some fine kindling across the two logs and some larger kindling across those, log cabin style. Light the newspaper.

### 4.3.4 USING FIRE STARTERS

Many people like to use commercial fire starters instead of newspaper. Some of these starters are made of sawdust and wax and others are specialized flammable solid chemicals. Follow the package directions for use.

Gel starter may be used but only if there are no hot embers present. Use only in a cold firebox to start a fire.

**DO NOT USE FLAMMABLE LIQUIDS SUCH AS GASOLINE, NAPHTHA, FUEL OIL, MOTOR OIL, OR AEROSOLS TO START OR REKINDLE THE FIRE.**

## 4.4 MAINTAINING WOOD FIRES

### 4.4.1 GENERAL ADVICE

Wood heating with a space heater is very different than other forms of heating. There will be variations in the temperature in different parts of the house and there will be variations in temperature throughout the day and night. This is normal, and for experienced wood burners these are advantages of zone heating with wood.

Do not expect steady heat output from your wood inbuilt. It is normal for its surface temperature to rise after a new load of wood is ignited and for its temperature to gradually decline as the fire progresses. This rising and falling of temperature can be matched to your household routines. For example, the area temperature can be cooler when you are active, such as when doing housework or cooking, and it can be warmer when you are inactive, such as when reading or watching television.

Wood burns best in cycles. A cycle starts when a new load of wood is ignited by hot coals and ends when that load has been consumed down to a bed of charcoal about the same size as it was when the wood was loaded. Do not attempt to produce a steady heat output by placing a single log on the fire at regular intervals. Always place at least three, and preferably more, pieces on the fire at a time so that the heat radiated from one piece helps to ignite the pieces next to it. Each load of wood should provide several hours of heating. The size of each load can be matched to the amount of heat needed.

When you burn in cycles, you rarely need to open the wood inbuilt's loading door while the wood is flaming. This is an advantage because there is more chance that smoke will leak from the wood inbuilt when the door is opened as a full fire is burning.

**IF YOU MUST OPEN THE DOOR WHILE THE FUEL IS FLAMING, OPEN THE AIR CONTROL FULLY FOR A FEW MINUTES, THEN UNLATCH AND OPEN THE DOOR SLOWLY.**

#### 4.4.2 ASH REMOVAL

Ash should be removed from the firebox every two or three days of full time heating. Do not let the ash build up in the firebox because it will interfere with proper fire management.

The best time to remove ash is after an overnight fire when the wood inbuilt is relatively cool, but there is still some flue system draft to draw the ash dust into the wood inbuilt and prevent it from coming into the room.

**NOTE:** The blower should be turned in "OFF" position (2) prior to ash removal to avoid ashes to be pulled towards the inbuilt and then pushed into the room.

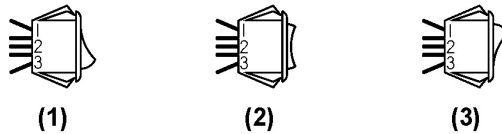

After ashes have been removed from the wood inbuilt and placed in a tightly covered metal container, they should be taken outside immediately. The closed container of ashes should be placed on a non-combustible floor or on the ground well away from all combustible materials pending final disposal. Ashes normally contain some live charcoal that can stay hot for several days. If the ashes are disposed of by burial in soil or otherwise locally dispersed, they should be retained in the closed container until all cinders have thoroughly cooled. Other waste shall not be placed in this container.

**NEVER STORE ASHES INDOORS OR IN A NON-METALIC CONTAINER OR ON A WOODEN DECK.**

#### 4.4.3 RAKING CHARCOAL

Rekindle the fire when you notice that the room temperature has fallen. You will find most of the remaining charcoal at the back of the firebox, furthest from the door. Rake these coals towards the door before loading. There are two reasons for this raking of the coals. First, it concentrates them near where most of the combustion air enters the firebox and where they can ignite the new load quickly, and second, the charcoal will not be smothered by the new load of wood. If you were to simply spread the charcoal out, the new load will smoulder for a long time before igniting.

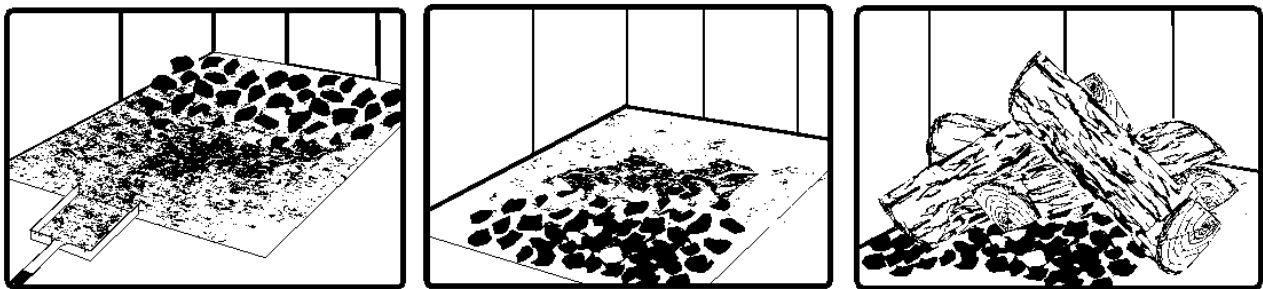

*Remove ash first, and then rake charcoal towards the front of the firebox before loading so that it will ignite the new load.*

#### 4.4.4 FIRING EACH NEW LOAD HOT

Place the new load of wood on and behind the charcoal and not too close to the glass. Close the door and open the air control fully. Leave the air control fully open until the firebox is full of flames, the wood has charred to black and its edges are glowing red. Firing each load of wood hot accomplishes a few things:

- drives the surface moisture from the wood,
- creates a layer of char on the wood, which slows down its release of smoke,
- heats the firebox components so they reflect heat back to the fire, and
- heats the flue system so it can produce strong, steady draft for the rest of the cycle.

Although it is important to fire each new load hot to prepare for a clean burn, do not allow the fire to burn at full intensity for more than a few minutes.

**DO NOT LEAVE THE WOOD INBUILT UNATTENDED WHILE A NEW LOAD IS BEING FIRED HOT.**

**DO NOT OVERFIRE.**

When you burn a new load of wood hot to heat up the wood, the wood inbuilt and the flue system, the result will be a surge of heat from the wood inbuilt. This heat surge is welcome when the room temperature is a little lower than desirable, but not welcome if the space is already warm. Therefore, allow each load of wood to burn down so that the space begins to cool off a little before loading. Letting the space cool before loading is one of the secrets to clean burning and effective zone heating.

#### 4.4.5 TURNING DOWN THE AIR SUPPLY

Once the firewood, firebox and flue system are hot, you can begin to reduce the air supply for a steady burn.

As you reduce the air supply to the fire, two important things happen. First, the firing rate slows down to spread the heat energy in the fuel over a longer period of time. Second, the flow rate of exhaust through the wood inbuilt and flue slows down, which gives more time for the transfer of heat from the exhaust. You will notice that as you reduce the air setting, the flames slow down. This is your indication that the wood inbuilt is burning at its peak efficiency.

If the flames get small and almost disappear when you turn down the air, you have turned down the air too early, or your firewood is wetter than it should be. With good fuel and correct air control use, the flames should slow down, but should stay large and steady, even as the air supply is reduced.

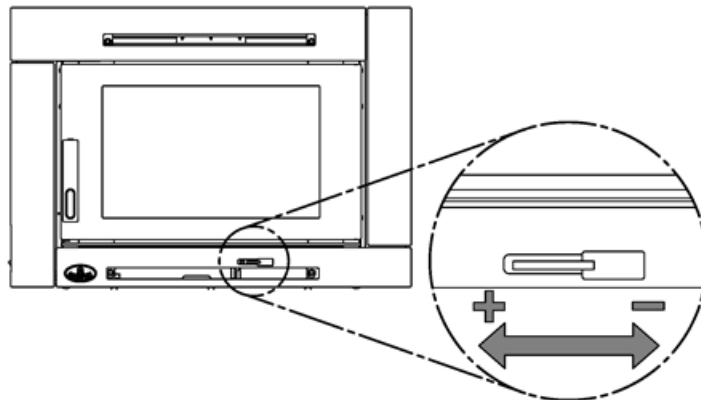

## 4.5 BLOWER OPERATION

Allow the wood inbuilt to reach operating temperature (approximately one hour), before turning on the blower, since increased airflow from the blower will remove heat and affect the start-up combustion efficiency.

The wood inbuilt's blower assembly is equipped with a heat sensor. Therefore, you can leave the switch in the automatic position (3). The blower will start automatically when the wood inbuilt is hot enough and it will stop when the wood inbuilt has cooled down. You can also set the switch to the manual position (1) to operate the blower at any time. Select the position (2) to manually stop the blower.

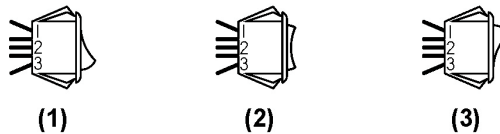

**NOTE: ENSURE THE BLOWER CORD IS NOT IN CONTACT WITH ANY SURFACE OF THE WOOD INBUILT TO PREVENT ELECTRICAL SHOCK OR FIRE DAMAGE. DO NOT RUN CORD BENEATH THE WOOD INBUILT.**

### 4.5.1 BUILDING DIFFERENT FIRES FOR DIFFERENT NEEDS

Using the air control is not the only way to match the wood inbuilt's heat output to the heat demand. Your house will need far less heat in April than in July to be kept at a comfortable temperature. If you fill the firebox full in fall weather, you will either overheat the space or turn the wood inbuilt down so much that the fire will be smoky and inefficient. Here are some suggestions for building fires to match different heat demand.

#### 4.5.1.1 Small Fires to Take the Chill Off the House

To build a small fire that will produce a low heat output, use small pieces of firewood and load them crisscross in the firebox. The pieces should be only 75 mm to 100 mm in diameter. After raking the coals, you can lay two pieces parallel to each other corner to corner in the firebox and lay two more across them in the other direction. Open the air control fully and only reduce the air after the wood is fully flaming. This kind of fire is good for mild weather when you are around to tend the wood inbuilt and should provide enough heat for four hours or more. Small fires like this are a good time to use softer wood species so there will be less chance of overheating the house.

#### 4.5.1.2 Long Lasting Low Output Fires

Sometimes you will want to build a fire to last up to eight hours, but don't need intense heat. In this case use smaller pieces of hardwood and place the logs compactly in the firebox so the pieces are packed tightly together. You will need to fire the load hot for long enough to fully char the log surfaces before you can turn the air down. Make sure the fire is flaming brightly before leaving the fire to burn.

#### **4.5.1.3 High Output Fires for Cold Weather**

When the heat demand is high during cold weather, you'll need a fire that burns steadily and brightly. This is the time to use your biggest pieces of hardwood fuel if you have it. Put the biggest pieces at the back of the firebox and place the rest of the pieces compactly. A densely built fire like this will produce the longest burn your wood inbuilt is capable of.

You will need to be cautious when building fires like this because if the air is turned down too much, the fire could smoulder. Make sure the wood is flaming brightly before leaving the fire to burn. The wood should be positioned in a north/south fashion, that is, from the front to the back of the firebox.

#### **4.5.1.4 Maximum Burn Cycle Times**

The burn cycle time is the period between loading wood on a coal bed and the consumption of that wood back to a coal bed of the same size. The flaming phase of the fire lasts for roughly the first half of the burn cycle and the second half is the coal bed phase during which there is little or no flame. The length of burn you can expect from your wood inbuilt, including both the flaming and coal bed phases, will be affected by a number of things, such as:

- firebox size,
- the amount of wood loaded,
- the species of wood you burn,
- the wood moisture content,
- the size of the space to be heated,
- the climate zone you live in, and
- the time of year.

The table below provides a very general indication of the maximum burn cycle times you are likely to experience, based on firebox volume.

<b>FIREBOX VOLUME</b>	<b>MAXIMUM BURN TIME</b>
< 0.042 cubic meter	3 to 5 hours
0.042 m <sup>3</sup> to 0.056 m <sup>3</sup>	5 to 6 hours
0.056 m <sup>3</sup> to 0.071 m <sup>3</sup>	6 to 8 hours
0.071 m <sup>3</sup> to 0.085 m <sup>3</sup>	8 to 9 hours
> 0.085 m <sup>3</sup>	9 to 10 hours

Long burn times are not necessarily an indication of efficient wood inbuilt operation. When you are home during the day and able to tend the fire, it is preferable to build a smaller fire that might provide three or four hours of heating than to fully load the firebox for a much longer burn. Shorter burn cycles make it easier to match the heat output of the wood inbuilt to the heat demand of the space.

## 5 MAINTAINING YOUR WOOD HEATING SYSTEM

### 5.1 WOOD INBUILT MAINTENANCE

Your new wood inbuilt will give many years of reliable service if you use and maintain it correctly. Some of the internal components of the firebox, such as firebricks, baffles and air tubes, will wear over time under intense heat. You should always replace defective parts with original parts (see **Appendix 8: Exploded Diagram and Parts List**). For firing each load hot to begin a cycle as described above will not cause premature deterioration of the wood inbuilt. However, letting the wood inbuilt run with the air control fully open for entire cycles can cause damage over time. The hotter you run the wood inbuilt throughout burn cycles, the more quickly its components will deteriorate. For that reason, **never leave the wood inbuilt unattended while a new load is being fired hot.**

#### 5.1.1 CLEANING DOOR GLASS

Under normal conditions, your door glass should stay relatively clear. If your firewood is dry enough and you follow the operating instructions in this manual, a whitish, dusty deposit will form on the inside of the glass after a week or so of use. This is normal and can be easily removed when the wood inbuilt is cool by wiping with a damp cloth or paper towel and then drying. **Never try to clean the glass when the wood inbuilt is hot.**

In spring and fall when the wood inbuilt is run at lower temperatures, you may see some light brown stains forming, especially at the lower corners of the glass. This indicates that the fire has been smoky and some of the smoke has condensed on the glass. When the weather is mild, you may find that letting the fire go out is better than trying to maintain a continuous fire. Use the technique described above for building a fire to take the chill off the house.

If you do get brown stains on the glass you can remove them with special cleaners for wood inbuilt glass doors. **Do not use abrasives to clean your wood inbuilt's door glass.**

The deposits that form on the glass are the best indication of the quality of your fuel and how well you are doing in operating the wood inbuilt. Your goal should be clear glass with no brown stains. If you continue to see brown stains on the glass, something about your fuel and operating procedure needs to be changed. Stains on the glass indicate incomplete combustion of the wood, which also means more smoke emissions and faster formation of creosote in the flue system.

If you see brown streaks coming from the edge of the glass, it is time to replace the gasket around the glass. Visit your wood inbuilt retailer to get the self-adhesive glass gasket and follow the instructions below for installation.

### 5.1.2 DOOR ADJUSTMENT

In order for your wood inbuilt to burn at its best efficiency, the door must provide a perfect seal with the firebox. Therefore, the gasket should be inspected periodically making sure to obtain an air tight fit. Airtightness can be improved with a simple latch mechanism adjustment. To increase the pressure on the gasket, remove one washer (B). To reduce pressure on the door, when putting a new door gasket for example, put two washers. To adjust:

1. Unscrew the two screws (A) and remove/add one spacer (B).
2. Reinstall the handle guide with the screws (A)

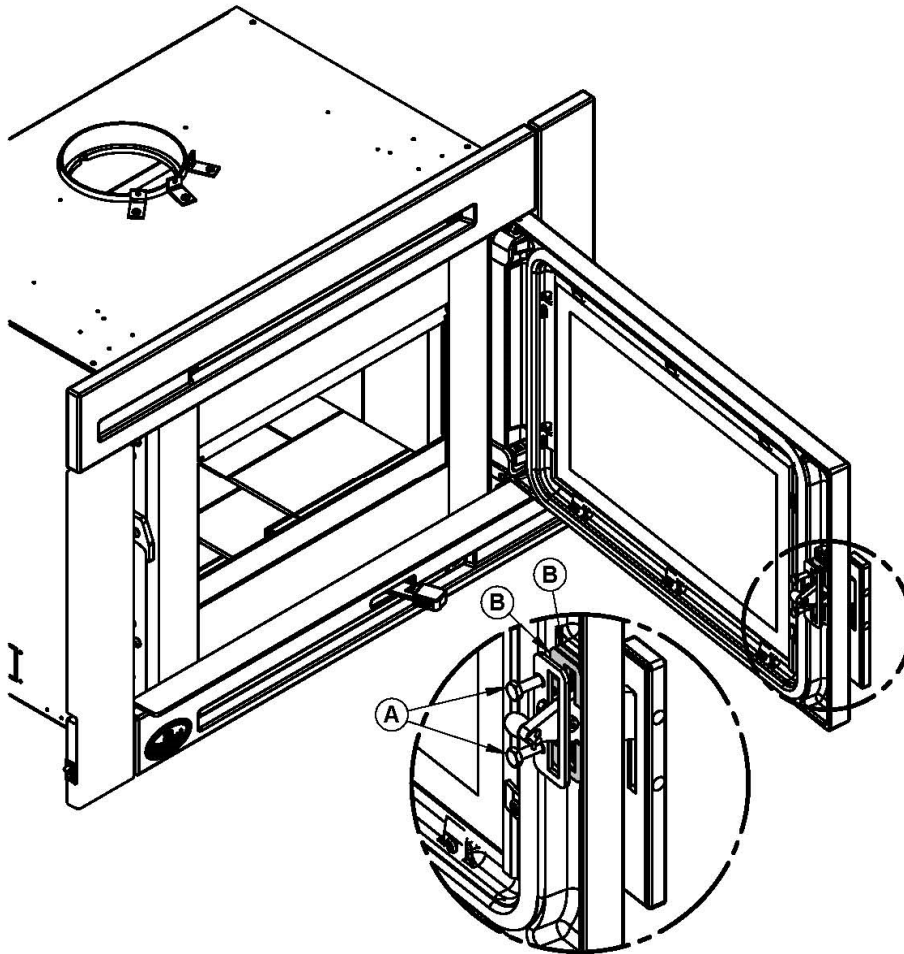

### 5.1.3 REPLACING THE DOOR GASKET

It is important to maintain the gasket in good condition. After a year or more of use, the door gasket will compress and become hard, which may allow air to leak past it. You can test the condition of the door gasket by closing and latching the door on a strip of paper. Test all around the door. If the paper slips out easily anywhere, it is time to replace the gasket.

Use the correct replacement gasket that you can purchase from your retailer. The diameter and density of the gasket is important to getting a good seal.

Place the door face-down on something soft like a cushion of rags or piece of carpet. Remove the old gasket from the door by pulling and prying it out with an old screw driver. Then use the screwdriver to scrape the old gasket adhesive from the door. Now run a 6 mm (1/4") bead of high temperature silicone in the door gasket groove. Starting from the middle of the hinge side, press the gasket into the groove. Do not stretch the gasket as you place it. Leave the gasket about 12 mm (1/2") long when you cut it and press the end into the groove. Tuck any loose fibres under the gasket and into the silicone. Close the door and do not use the wood inbuilt for 24 hours.

### 5.1.4 REPLACING THE GLASS GASKET AND/OR THE GLASS

It is a good idea to replace the glass gasket when the door gasket is replaced. The gasket is flat, adhesive-backed, woven fibreglass. Remove the glass retaining screws (A) and clips (B) then both metal frames (C) that holds the glass to the door frame (E). Lift out the glass (D) and pull off the old gasket. This is a good time to clean the glass thoroughly.

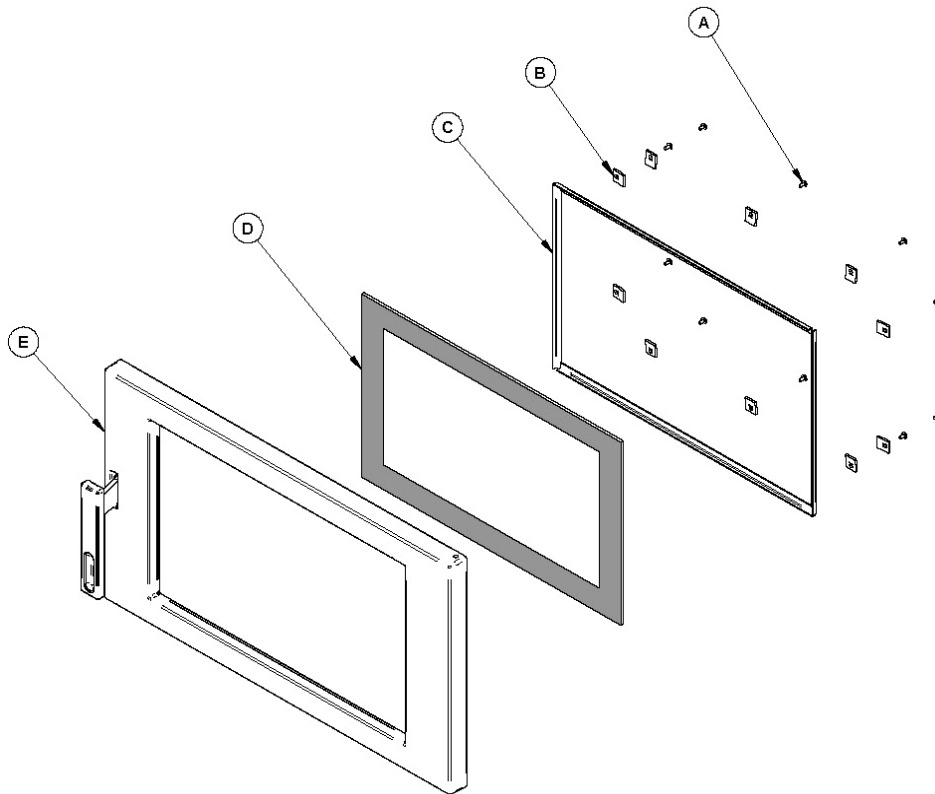



The gasket must be centered on the edge of the glass. To do this easily, peel back a section of the paper covering the adhesive and place the gasket on a table with the adhesive side up. Stick the end of the gasket to the middle of one edge, then press the edge of the glass down onto the gasket, taking care that it is perfectly centered on the gasket. Peel off more of the backing and rotate the glass and press the next section onto the gasket. Do not stretch the gasket as you place it. Continue until you get to the start and trim the gasket to length. Now pinch the gasket to the glass in a U shape, all around the glass. Reinstall the glass, being careful to centre the glass carefully in the door. Do not over-tighten the screws. Note that the two main causes of broken door glass are uneven placement in the door and over-tightening of retaining screws.

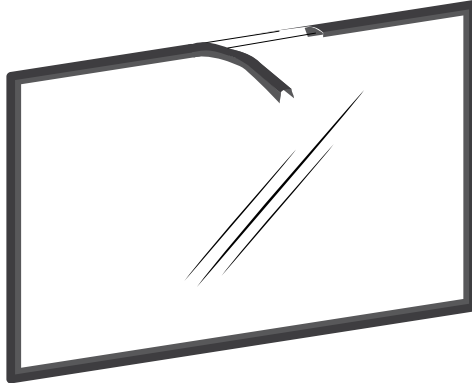

**Do not abuse the glass door by striking or slamming shut. Do not use the wood inbuilt if the glass is broken. To change the glass, perform the same operation described above.**

### 5.1.5 CLEANING AND PAINTING THE WOOD INBUILT

**Do not attempt to clean or paint the wood inbuilt when the unit is hot.** Painted surfaces can be wiped down with a damp cloth. Plated surfaces may be scratched by abrasive cleaners. To maintain the finish at its original brilliance, use only a damp soft cloth to clean plated surfaces.

If the paint becomes scratched or damaged, you can give your wood inbuilt a brand new look by repainting it with heat-resistant paint. Before painting, roughen the surface with fine sand paper, wipe it down to remove dust, and apply two thin coats of paint. For best results, use the same paint that was originally used on the wood inbuilt, which is available in spray cans. See your dealer for details.

## 5.2 FLUE AND FLUE LINER MAINTENANCE

### 5.2.1 WHY FLUE SYSTEM CLEANING IS NECESSARY

Wood smoke can condense inside the flue and flue system, forming a combustible deposit called creosote. If creosote is allowed to build up in the flue system it can ignite when a hot fire is burned in the wood inbuilt and a very hot fire can progress to the top of the flue system. Severe flue system fires can damage even the best flue systems. Smouldering, smoky fires can quickly cause a thick layer of creosote to form. When you avoid smouldering so the exhaust from the flue system is mostly clear, creosote builds up more slowly. Your new wood inbuilt has the right characteristics to help you to burn clean fires with little or no smoke, resulting in less creosote in the flue system.

### 5.2.2 HOW OFTEN SHOULD YOU CLEAN THE FLUE SYSTEM?

It is not possible to predict how much or how quickly creosote will form in your flue system. It is important, therefore, to check the build-up in your flue system monthly when getting used to the new wood inbuilt until you determine the rate of creosote formation. Even if creosote forms slowly in your system, the flue system should be cleaned and inspected at least once each year.

Contact your local municipal or provincial fire authority for information on how to handle a flue system fire. Have a clearly understood plan to handle a flue system fire.

### 5.2.3 CLEANING THE FLUE SYSTEM

Flue system cleaning can be a difficult and dangerous job. If you don't have experience cleaning flue systems, you might want to hire a professional flue system sweep to clean and inspect the system for the first time. After having seen the cleaning process, you can decide if it is a job you would like to take on.

The most common equipment used are fibreglass rods with threaded fittings and stiff plastic brushes. The brush is forced up and down inside the flue system to scrub off the creosote.

The flue system should be checked regularly for creosote build-up. Inspection and cleaning of the flue system can be facilitated by removing the baffle.



**CAUTION: OPERATION OF YOUR MATRIX WOOD INBUILT WITHOUT THE BAFFLE MAY CAUSE UNSAFE AND HAZARDOUS TEMPERATURE CONDITIONS AND WILL VOID THE WARRANTY.**

**NOTE:** Before installing the firebrick, check to ensure that none are broken or damaged in any way. If so, have the damaged ones replaced. Check the firebrick for damage at least annually and replace any broken or damaged ones with new ones.

## PART B – INSTALLATION

### 6 PRE-INSTALLATION REQUIREMENTS

#### 6.1 MASONRY FIREPLACE

The masonry fireplace must meet the minimum requirements found in the building code enforced locally, or the equivalent for a safe installation. Contact your local Building Inspector for requirements in your area. An inspection of the fireplace should include the following:

1. **CONDITION OF THE FIREPLACE AND FLUE SYSTEM:**

The masonry fireplace and flue system should be inspected prior to installation, to determine that they are free from cracks, loose mortar, creosote deposits, blockage, or other signs of deterioration. If evidence of deterioration is noted, the fireplace or flue system should be upgraded and/or cleaned prior to installation.

Masonry or steel, including the damper plate, may be removed from the smoke shelf and adjacent damper frame if necessary to accommodate the wood inbuilt's flue liner, provided that their removal will not weaken the structure of the fireplace and flue system, and will not reduce protection for combustible materials to less than that required by the building code.

2. **FLUE SYSTEM CAPS:**

Mesh type flue system caps must have provision for regular cleaning, or the mesh should be removed to eliminate the potential of plugging.

3. **ADJACENT COMBUSTIBLES:**

The fireplace should be inspected to make sure that there is adequate clearance to combustibles, both exposed combustibles to the top, side, and front as well as concealed combustibles, in the flue system and mantle area. Your local inspector should have information on whether older fireplaces are of adequate construction.

4. **OPENING SIZE:**

Refer to "**MINIMUM MASONRY OPENING**" (Section 8.5) for suitable size fireplace openings.

#### 6.2 ZERO-CLEARANCE KIT

5. **INSTALLATION INTO AN EXISTING FACTORY-BUILT ZERO-CLEARANCE FIREPLACE:**

A 'built-in' appliance is designed to be in contact with or built into a heat sensitive structure within a building. These types of appliances must be tested in a laboratory in accordance with AS/NZS 2918 to ensure their compliance with safety requirements. There is no such thing as a 'standard' (untested) built-in appliance. As each model or appliance may have markedly different installation clearances and instructions, it is extremely important to follow the manufacturer's installation instructions, which are based on the laboratory tests results. **The Matrix inbuilt can only be installed with the Osburn Matrix zero-clearance kit (sold separately).** See installation instructions provided with the kit.

## 7 SAFETY INFORMATION

### 7.1 SUMMARY OF INSTALLATION CAUTIONS AND WARNINGS

- DISCONNECT THE BLOWER'S ELECTRIC POWER BEFORE SERVICING.
- THE INFORMATION GIVEN ON THE CERTIFICATION LABEL AFFIXED TO THE APPLIANCE ALWAYS OVERRIDES THE INFORMATION PUBLISHED, IN ANY OTHER MEDIA (OWNER'S MANUAL, CATALOGUES, FLYERS, MAGAZINES AND/OR WEB SITES).
- MIXING OF APPLIANCE OR FLUE-SYSTEM COMPONENTS FROM DIFFERENT SOURCES OR MODIFYING COMPONENTS MAY RESULT IN HAZARDOUS CONDITIONS. WHERE ANY SUCH CHANGES ARE PLANNED, THE MANUFACTURER SHOULD BE CONTACTED IN ADVANCE.
- CONNECT THIS WOOD INBUILT ONLY TO A TRIPLE SKIN FLUE KIT FOR USE WITH SOLID FUEL OR TO A LINED MASONRY FLUE SYSTEM CONFORMING TO NATIONAL AND LOCAL BUILDING CODES.
- USE SMOKE DETECTORS IN THE ROOM WHERE YOUR WOOD INBUILT IS INSTALLED.
- IF REQUIRED, A SUPPLY OF COMBUSTION AIR SHALL BE PROVIDED TO THE ROOM OR SPACE.
- KEEP FURNITURE AND DRAPES WELL AWAY FROM THE WOOD INBUILT.
- DO NOT CONNECT TO OR USE IN CONJUNCTION WITH ANY AIR DISTRIBUTION DUCTWORK UNLESS SPECIFICALLY APPROVED FOR SUCH INSTALLATION.
- DO NOT CONNECT THIS UNIT TO A FLUE OR FLUE SYSTEM SERVING ANOTHER APPLIANCE.
- THE WOOD INBUILT AND ITS STAINLESS STEEL FLUE LINER ARE TO BE INSTALLED ONLY WITHIN A LINED MASONRY FLUE SYSTEM AND MASONRY FIREPLACE CONFORMING TO BUILDING CODES FOR USE WITH SOLID FUEL. DO NOT REMOVE BRICKS OR MORTAR FROM THE EXISTING FIREPLACE WHEN INSTALLING THE WOOD INBUILT.

## 7.2 REGULATIONS COVERING WOOD INBUILT INSTALLATION

IT IS RECOMMENDED THAT THE INSTALLATION OF YOUR OSBURN WOOD INBUILT BE CARRIED OUT BY A QUALIFIED SPECIALIST INSTALLER. IF ANY ELECTRICAL WORK IS REQUIRED, IT MUST BE CARRIED OUT BY A LICENSED ELECTRICIAN.

**WARNING:** The instructions pertaining to the installation of your wood inbuilt comply with the AS/NZS 2918:2001 standard. **THE APPLIANCE AND FLUE SYSTEM MUST THEREFORE BE INSTALLED IN ACCORDANCE WITH AS/NZS 2918:2001 AND THE APPROPRIATE REQUIREMENTS OF THE RELEVANT BUILDING CODE OR CODES.**

**WARNING:** APPLIANCES INSTALLED IN ACCORDANCE WITH THIS STANDARD SHALL COMPLY WITH THE REQUIREMENTS OF AS/NZS 4012/4013 (1999) WHERE REQUIRED BY THE REGULATORY AUTHORITY, I.E. THE APPLIANCE SHALL BE IDENTIFIABLE BY A COMPLIANCE PLATE WITH THE MARKING “TESTED TO AS/NZS 4012/4013 (1999)”.

ANY MODIFICATION OF THE APPLIANCE THAT HAS NOT BEEN APPROVED IN WRITING BY THE TESTING AUTHORITY IS CONSIDERED TO BE IN BREACH OF THE APPROVAL GRANTED FOR COMPLIANCE WITH AS/NZS 4012/4013 (1999).

**NOTE:** The wood inbuilt is not approved for use with a so-called “positive flue connection” to the clay tile of a masonry flue system.

## 8 CLEARANCES TO HEAT-SENSITIVE MATERIALS

The clearances shown in this section have been determined by test according to procedures set out in safety standards AS/NZS 2918:2001. When the wood inbuilt is installed so that its surfaces are at or beyond the minimum clearances specified, combustible surfaces will not overheat under normal and even abnormal operating conditions.

**No part of the wood inbuilt may be located closer to combustibles than the minimum clearance figures given.**

### 8.1 LOCATION OF THE CERTIFICATION LABEL

Since the information given on the certification label affixed to the appliance always overrides the information published, in any other media (owner's manual, catalogues, flyers, magazines and/or web sites) it is important to refer to it in order to have a safe and compliant installation. In addition, you will find information about your wood inbuilt (model, serial number, etc.). You can find the certification label on the side, towards the front of the outside of the air jacket of the inbuilt.

To access the certification label, the faceplate may need to be removed. Therefore, we recommend that you note the wood inbuilt's serial number on this manual, since it will be needed to precisely identify the version of the appliance in the event you require replacement parts or technical assistance.

### 8.2 POSITIONING THE UNIT

It is necessary to have a floor protection made of non-combustible materials that meets the measurements specified in table "**FLOOR PROTECTION**" (see **Section 8.3**). To determine the need to add floor protection (D) beyond the hearth extension, you must do the following calculation using the data in Table **Data for floor protection calculation** of this section:  $D = B - (A - C)$ . If the value (D) is negative or zero, you do not have to add more floor protection in front of the unit, because the masonry fireplace hearth extension is large enough. If the value (D) is positive, you will need floor protection in front of the hearth extension at least equivalent to the result (D).

Here is a sample calculation to determine the need to add a non-combustible materials floor protection. For someone whose wood inbuilt would protrude 76 mm into the room (C) the calculation would be:

$$\text{Value D} = B - (A - C)$$

$$\text{Value D} = 500 \text{ mm} - (416 \text{ mm} - 76 \text{ mm})$$

$$\text{Value D} = 500 \text{ mm} - 340 \text{ mm}$$

$$\text{Value D} = \mathbf{160 \text{ mm}}$$

Non-combustible floor protection of at least **160 mm** in depth must be installed in front of the fireplace hearth extension.

If non-combustible material floor protection needs to be added in front of the hearth extension of the masonry fireplace, it must be made of cement sheet or similar material with a thermal conductivity of 0,8 m<sup>2</sup>.K/W per 4 mm thick and have a thickness of 24 mm. The floor protection should be 1070 mm deep (D) x 945 mm width (W)

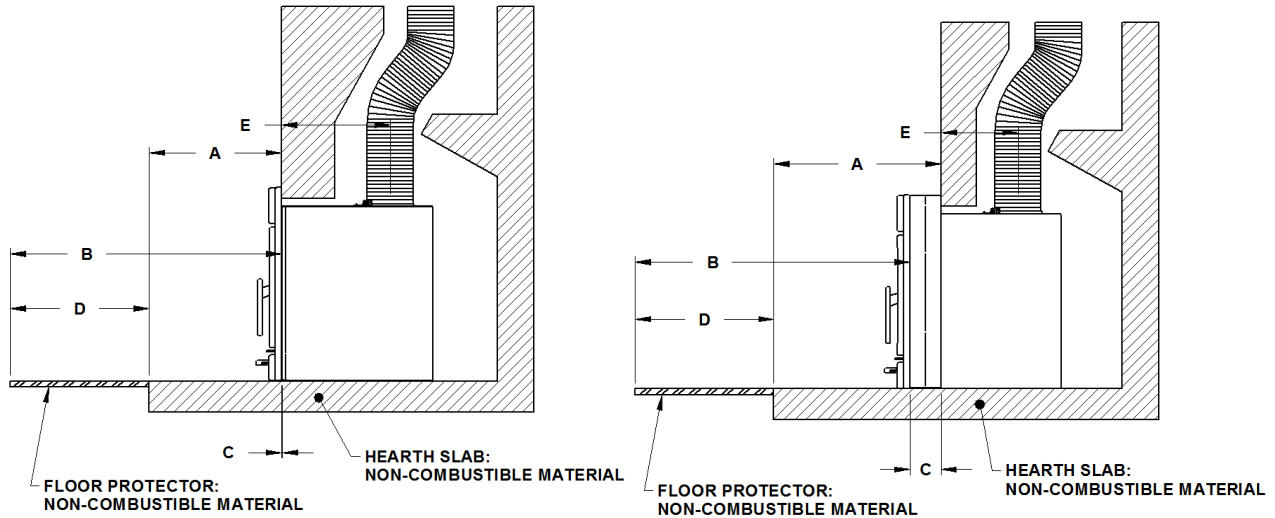

The standard configuration of the wood inbuilt leaves no projection of the convection air jacket in front of the fireplace opening. Therefore the minimum projection is 0". Although it is possible to position the wood inbuilt to obtain a projection of 51 mm (2") or 102 mm (4") of the convection air jacket in front of the fireplace opening with the use of the "PROJECTION KIT" option AC01323. The choice of the configuration will depend on, the previous installation instructions and compliance with building code. To determine the minimum and maximum projection of the wood inbuilt, refer to table **Data for floor protection calculation**.

Data for Floor Protection Calculation

MINIMUM EXTENDED	A	B (Note 1)	C	D	AIR JACKET
MILLIMETRES	Dimension of the hearth extension	500 mm	0 mm	$D = B - (A - C)$	Flush with fireplace facing

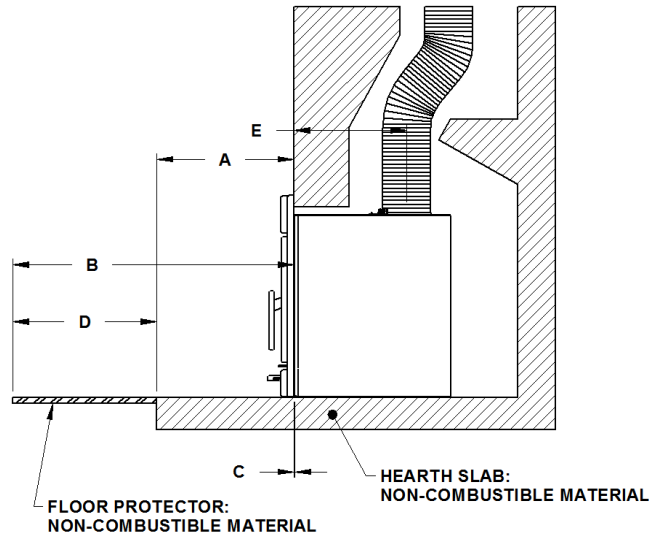

MAXIMUM EXTENDED	A	B (Note 1)	C	D	AIR JACKET
MILLIMETRES	Dimension of the hearth extension	500 mm	51 or 102 mm	$D = B - (A - C)$	Back from fireplace facing 51 or 102 mm

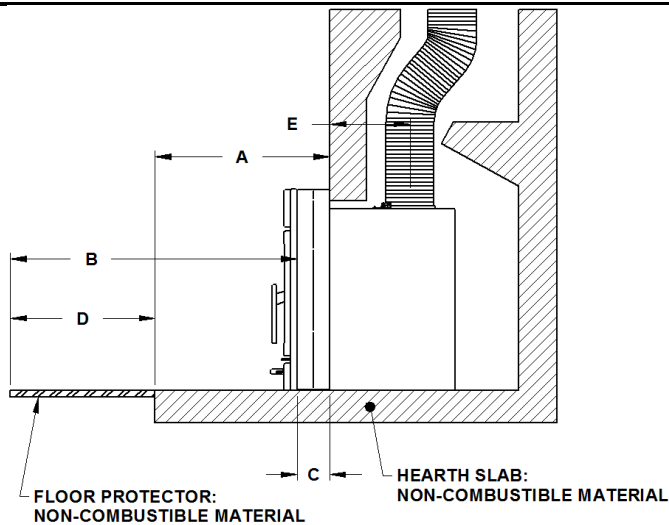



### 8.3 MINIMUM MASONRY OPENING, CLEARANCES TO COMBUSTIBLES, AND FLOOR PROTECTOR

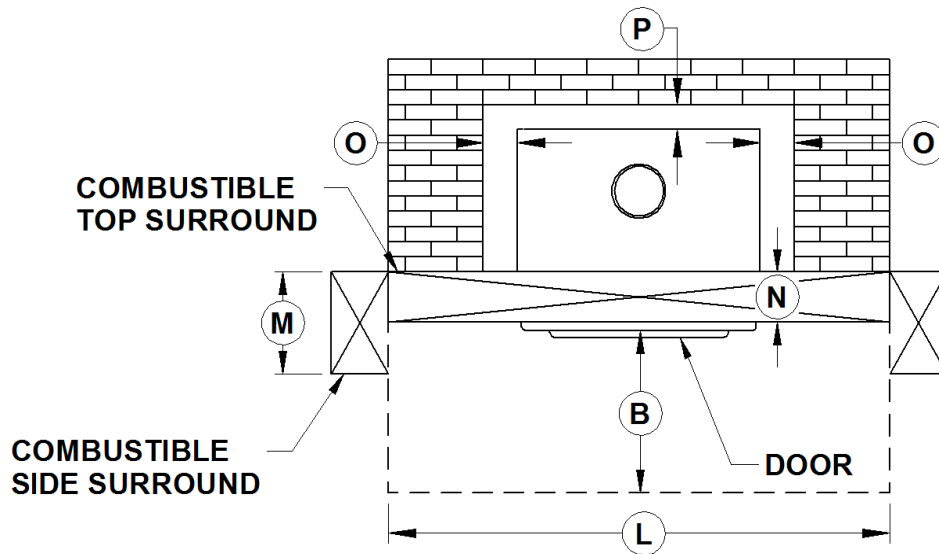
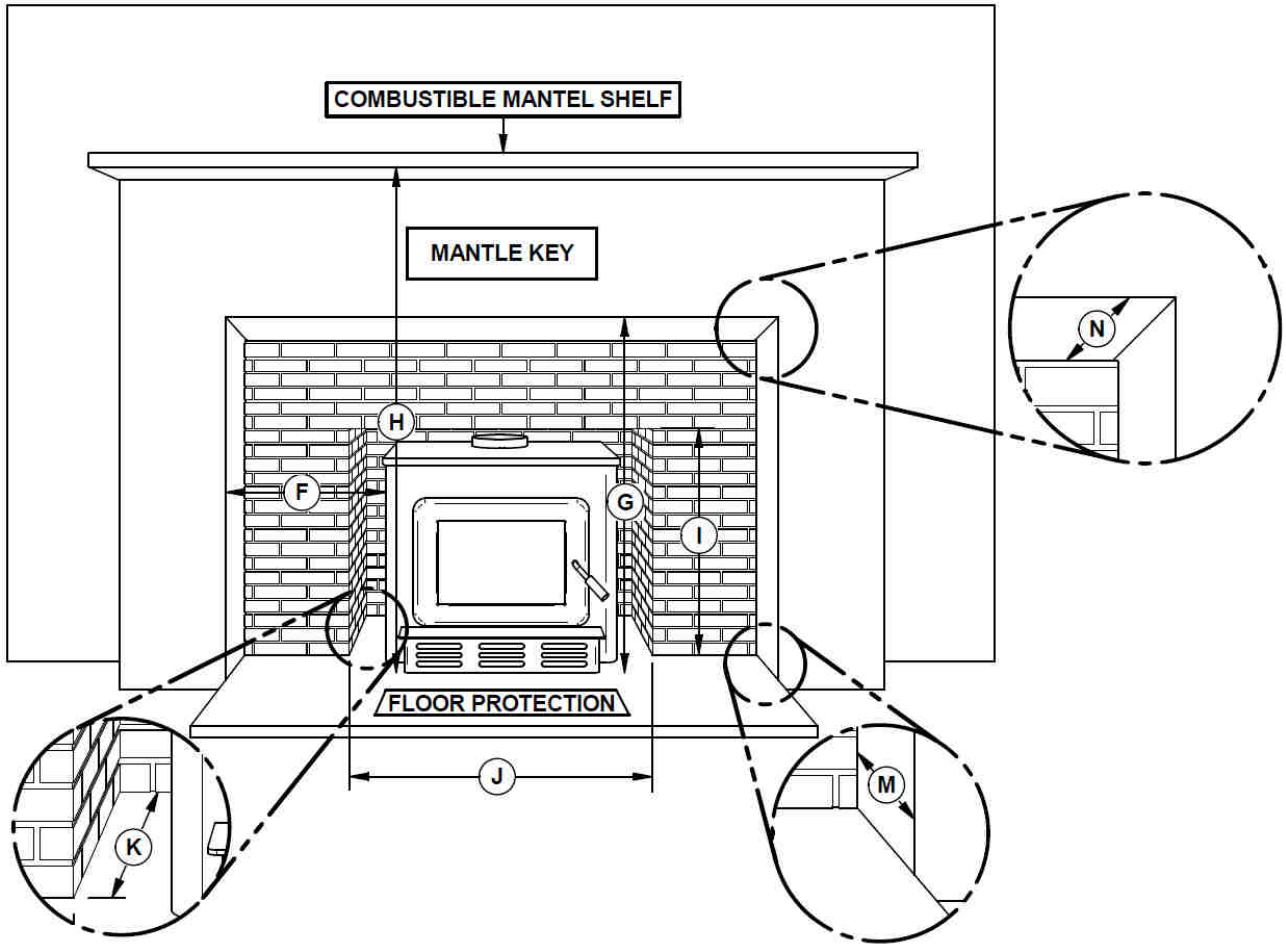

CLEARANCES	
<b>F</b>	80 mm
<b>G</b>	1250 mm
<b>H</b>	1340 mm*

MAXIMUM PROTRUSION	
<b>M</b>	40 mm
<b>N</b>	40 mm

MINIMUM MASONRY OPENING	
<b>I</b>	622 mm
<b>J</b>	781 mm**
<b>K</b>	439 mm ***
<b>O</b>	30 mm
<b>P</b>	30 mm

FLOOR PROTECTION	
<b>B</b>	500 mm
<b>L</b>	975 mm

- \* For a 250 mm mantel shelf.
- \*\* Where a fresh air intake is needed, we suggest you add a minimum of 102 mm (4") to the width of the minimum masonry opening.
- \*\*\* If projection kit AC01323 (sold separately) is used **L** = 439 mm. If installed without projection kit **L** = 541 mm.

**Note 1:** From door opening. The depth of the hearth extension in front of the wood inbuilt is included in the calculation of the floor protector's dimensions.

**Note 2:** A min 80 mm air gap between the flue outer casing and the first timber stud above the fireplace insert is required.

**Note 3:** The first internal wall stud must be 150 mm above the fireplace insert top and the front wall up to that first stud must be made of non-combustible material.

## 9 THE FLUE SYSTEM

### 9.1 GENERAL

The flue system, made up of the flue system and the flue between the wood inbuilt and the flue system, acts as the engine that drives your wood heating system. Even the best wood inbuilt will not function safely and efficiently as intended if it is not connected to a suitable flue system.

The heat in the flue gases that pass from the wood inbuilt and flue into the flue system is not waste heat. This heat is what the flue system uses to make the draft that draws in combustion air, keeps smoke inside the wood inbuilt and safely vents exhaust to outside. You can think of heat in the flue gas as the fuel the flue system uses to make draft.

### 9.2 SUITABLE FLUE SYSTEMS

Your wood inbuilt will provide optimum efficiency and performance when connected to a 150 mm diameter flue liner. The reduction of liner diameter to less than 150 mm should only be done if the total height of the masonry flue system is greater than 20 feet.

### 9.3 LINER INSTALLATION

For appliances discharging combustion products through a chimney, the chimney shall be inspected for soundness and thoroughly cleaned before a flue pipe is installed. The air gap between the flue pipe and the chimney shall be open at the top of the chimney to the extent that the total opening area is not less than 10 000 mm<sup>2</sup>. The chimney exit shall be fitted with means to prevent significant ingress of water and debris, and such means shall be constructed and fitted to maintain a total opening area at the chimney exit of not less than 10 000 mm<sup>2</sup>.

The flue pipe to inbuilt used in the chimney shall comply with AS/NZS 2918.

In order to connect the wood inbuilt to the flue liner, refer to **Section 9.4 Flue liner installation**.

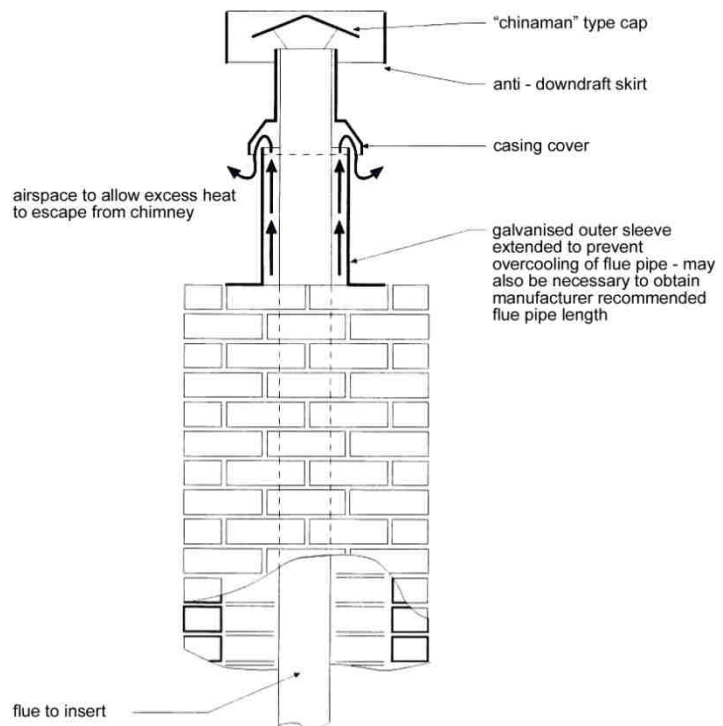

**ATTENTION INSTALLER:** When positioning the unit in a fireplace opening prior to the flue installation, install the wood inbuilt into the opening until the top lip of air jacket is flush with fireplace facing.

If lag-bolts or anchors are to be used to secure the wood inbuilt, the hole locations should be marked with the unit in place. Remove the wood inbuilt and locate the anchors.

## 9.4 FLUE LINER INSTALLATION

The preferred methods for installing the flue liner are found in **Section 9.5.1**. Use a liner offset adapter (**Section 9.5.2**) only as a last resort.

### 9.4.1 IF THE FLUE LINER DOES ALIGN WITH THE WOOD INBUILT'S FLUE OUTLET, YOU HAVE TWO OPTIONS

- A) Install the flue liner starter adapter, provided with the flue liner. Follow the flue liner starter adapter manufacturer's instructions.

In order to connect the flue liner starter adapter to the flue outlet, you can install the brackets with the screws that are in the owner's manual kit.

Using a powered driver, secure the three brackets with the three screws provided (30131) on top of the wood inbuilt in the three holes in front of the flue outlet. The long end of the brackets must be attached to the wood inbuilt. Insert the flue liner into the flue collar of the unit and secure the liner to the brackets with three self-tapping screws (not included).

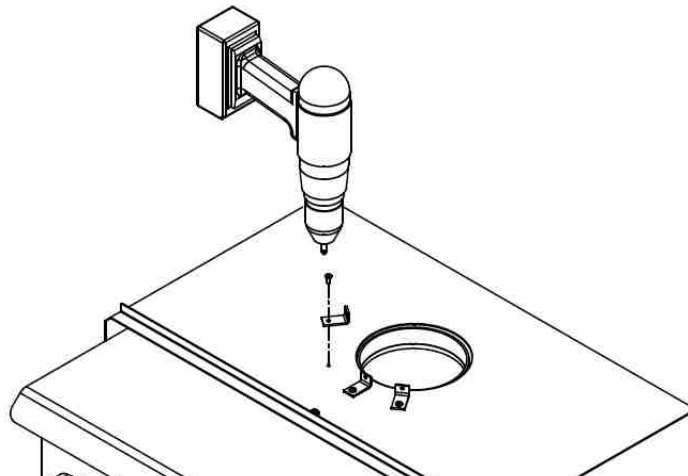

- B) Your dealer may offer a liner fastening system (AC02006), sold separately. Follow the installation instructions provided with the liner fastening system.

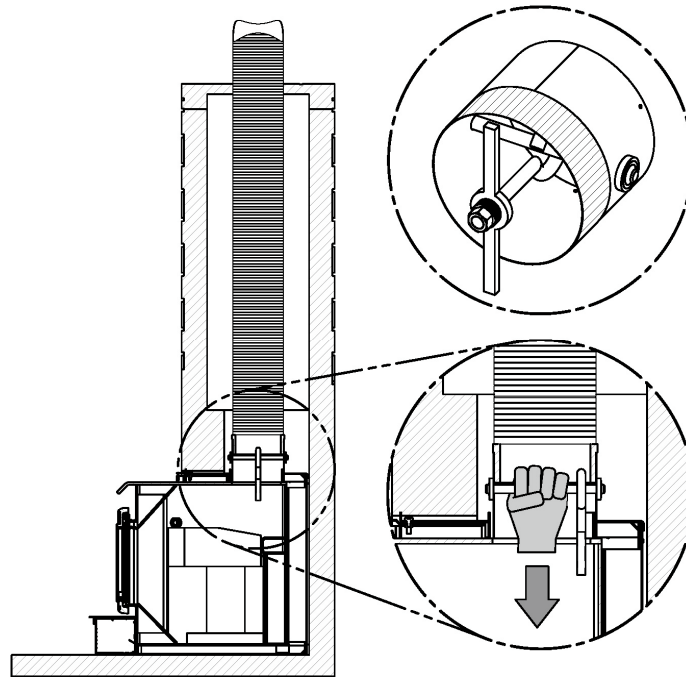

**9.4.2 IF THE FLUE LINER DOES NOT ALIGN WITH THE WOOD INBUILT'S FLUE OUTLET**

You can install a liner offset adaptor (AC01370), which is sold separately. Please note that an offset adaptor reduces the free flow of exhaust gases and may result in smoke roll-out from the wood inbuilt when it's door is opened for loading. Only use an offset adaptor if a) there is no other alternative and b) if the total height of the fireplace and flue system is at least 20 feet. If you must install a liner offset adaptor, secure the three brackets with the three screws provided (30131) on top of the wood inbuilt in the three holes in front of the flue outlet. The long end of the brackets must be attached to the wood inbuilt. The brackets and screws are in the wood inbuilt's owner's manual kit. Then follow the instructions in the manual provided with the liner offset adapter kit.

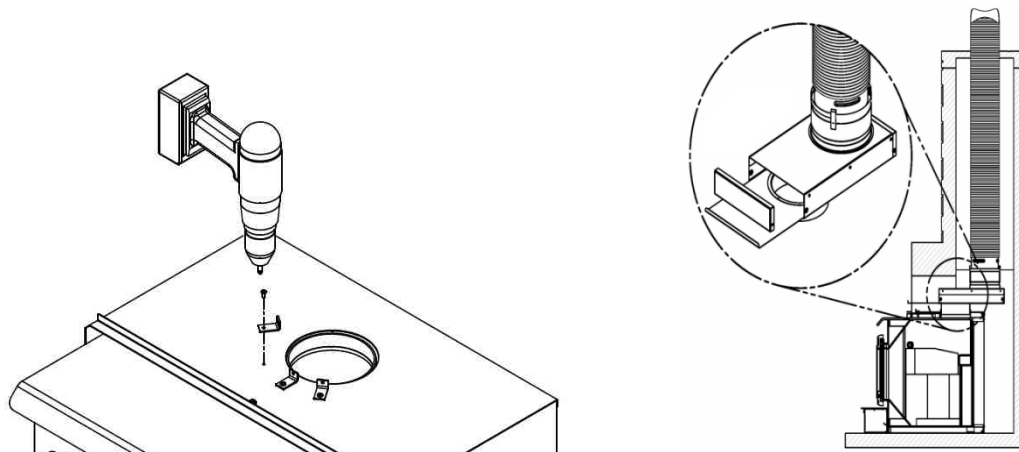

## 9.5 MINIMUM FLUE SYSTEM HEIGHT

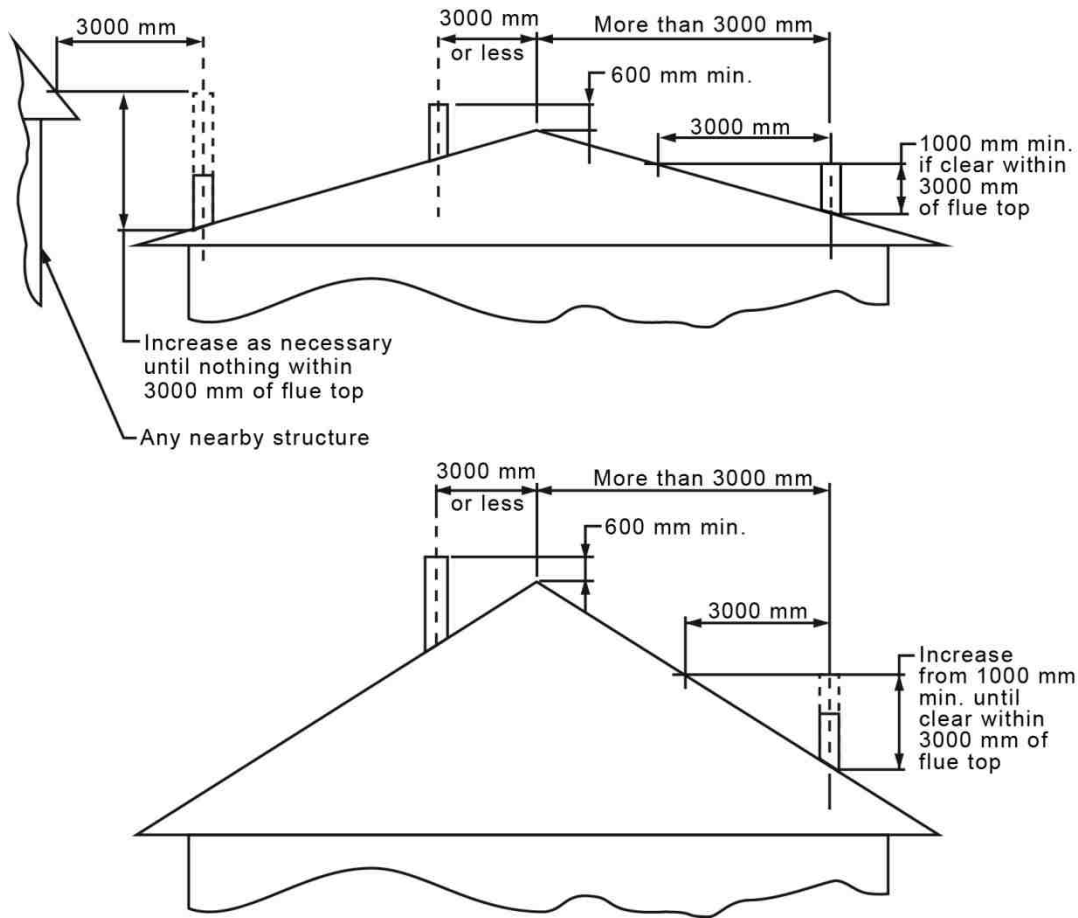

**Flue heights and lengths from AS/NZS 2918:2001**

The top of the flue system should be tall enough to be above the air turbulence caused when wind blows against the house and its roof.

The flue exit shall be located outside the building in which the appliance is installed so that:

- a) The flue shall extend not less than 4.6 m above the top of the floor protector;
- b) The minimum height of the flue system within 3 m distance from the highest point of the roof shall be 600 mm above that point;
- c) The minimum height of the flue system further than 3 m from the highest point of the roof shall be 1000 mm above roof penetration;
- d) No part of any building lies in or above a circular area described by a horizontal radius of 3 m about the flue system exit.

## 9.6 THE RELATIONSHIP BETWEEN THE FLUE SYSTEM AND THE HOUSE

Because the flue system is the engine that drives the wood heating system, it must have the right characteristics. The signs of bad system design are cold backdrafting when there is no fire in the wood inbuilt, slow kindling of new fires, and smoke roll-out when the door is opened for loading.

### 9.6.1 WHY THE FLUE SYSTEM SHOULD PENETRATE THE HIGHEST HEATED SPACE

When it is cold outside, the warm air in the house is buoyant so it tends to rise. This tendency of warm air to rise creates a slight pressure difference in the house. Called 'stack effect', it produces a slightly negative pressure low in the house (relative to outside) and a slightly positive pressure zone high in the house. If there is no fire burning in a heater connected to a flue system that is shorter than the warm space inside the house, the slight negative pressure low in the house will compete against the desired upward flow in the flue system.

There are two reasons why the flue system in the house at right will cold downdraught when it is cold outside and there is no fire burning in the wood inbuilt. First, the flue system runs up the outside of the house, so the air in it is colder and denser than the warm air in the house. And second, the flue system is shorter than the heated space of the house, meaning the negative pressure low in the house will pull outside air down the flue system, through the wood inbuilt and into the room. Even the finest wood inbuilt will not work well when connected to this flue system.



## 9.7 AIR QUALITY IN THE HOUSE

To protect against the risk of smoke spillage due to house depressurization, a **carbon monoxide (CO) detector/alarm is required** in the room in which the wood inbuilt is installed. The CO detector will provide warning if for any reason the wood inbuilt fails to function correctly.

## APPENDIX 1: REVERSING THE DOOR OPENING AND ADJUSTING THE HANDLE

The Matrix wood inbuilt is equipped with a reversible door in case you prefer a door opening on the other side. Follow the steps below if you wish to avail yourself of this feature:

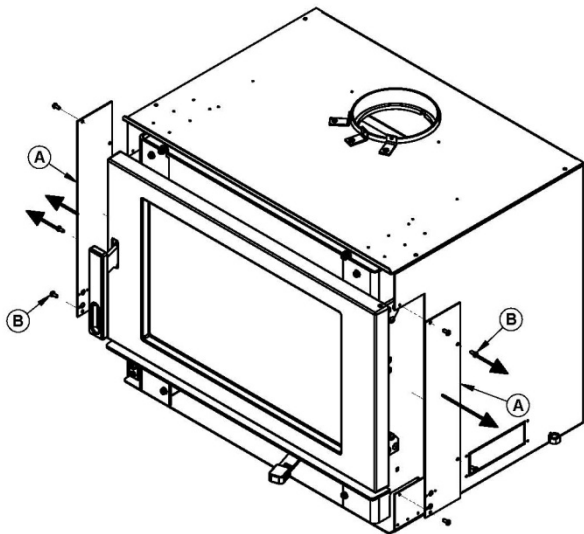

1. Remove the latch and hinge access plate (A) by unscrewing screws (B).

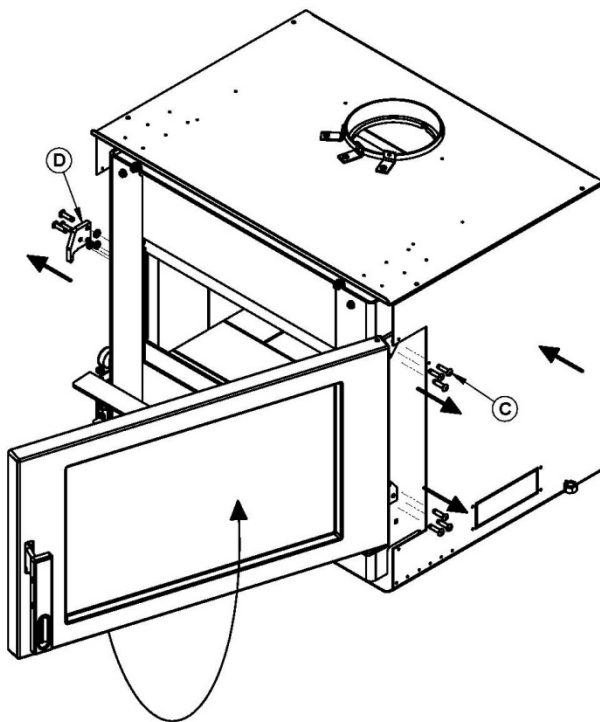

2. Remove the latch (D) and reinstall the screws that were securing the assembly into the holes.

**Note:** To avoid dropping the door due to its weight, get help from another person to perform the following steps.

3. Remove screws (C) securing the hinges to the firebox.
4. Rotate the door over 180 degree and secure the hinges on the other side. It is important to reinstall the screws in the holes left by removal of the door.



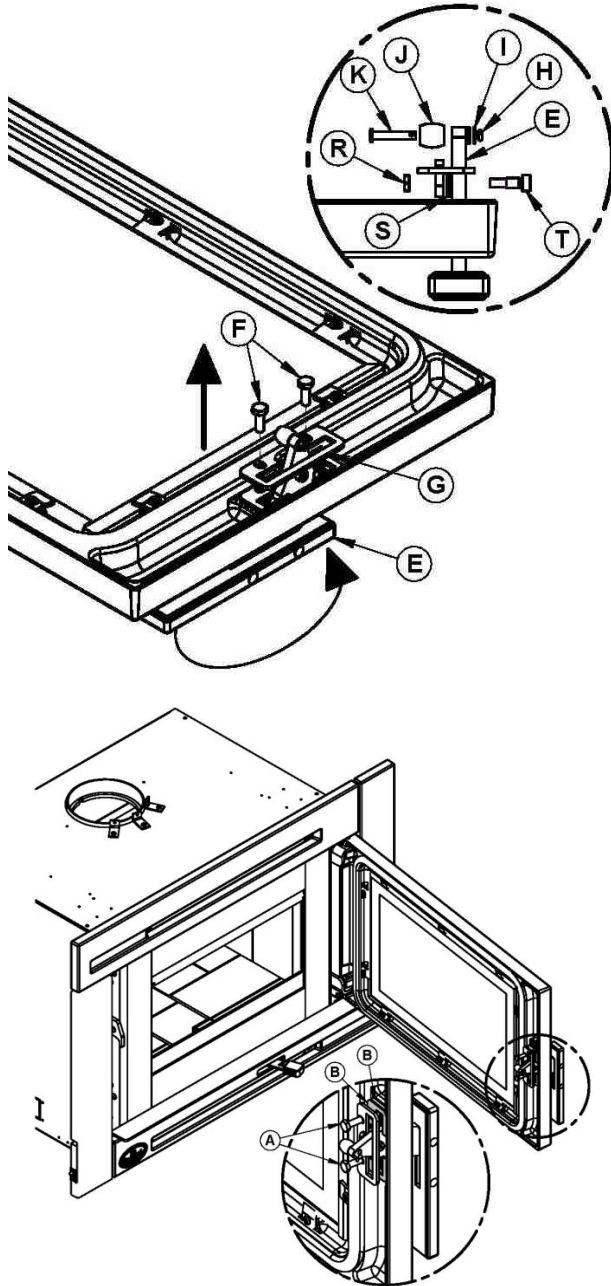

1. To reverse the door handle (E), remove the spring pin (H), the 2 washer (I), and the assembled balled latch (J) and the cylindrical pin (K).
2. Unscrew the 2 bolts (F) that holds the handle guide (G) in place. Remove the spacers (B).
3. Unscrew the lock nut (R) first, and then the shoulder screw (T) that holds the door handle (E) and the washer (S) on the handle guide (G).
4. Remove the door handle (E), rotate it a half turn and reinstall it in the same location. Put back the spacers (B).
5. Assemble the handle guide (G) along with the washer (S) on the door handle (E) with the shoulder screw (T) and the nut (R). Make sure the parts are properly assembled.
6. Secure the handle guide (G) with the 2 bolts (F).
7. Reinstall the assembled cylindrical pin (K) and balled latch (J), along with the 2 washer (I) and secure with the spring pin (H).

To adjust the tightness of the door, see **Section 5.1.2 Door adjustment.**

## APPENDIX 2: INSTALLING THE OPTIONAL FRESH AIR INTAKE KIT (AC01298)

**Note:** Only remove the knock-out that will be connected to the fresh air inlet.

To install a fresh air intake kit to the wood inbuilt, the purchase of accessory AC01298 is required.

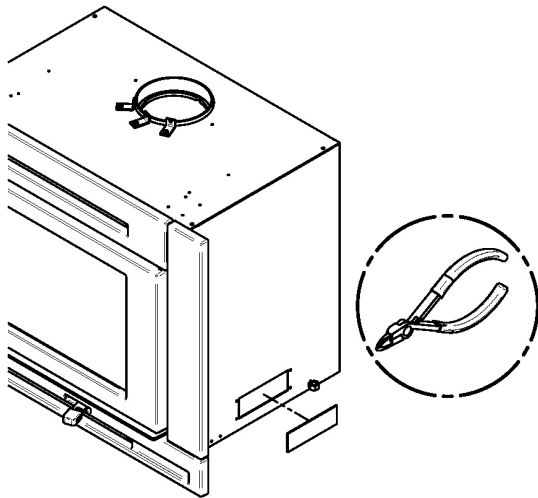

Using pliers, remove the rectangular knock-out plate (A) located on the left or right side of the convection air jacket. Choose the side that is best for your installation.

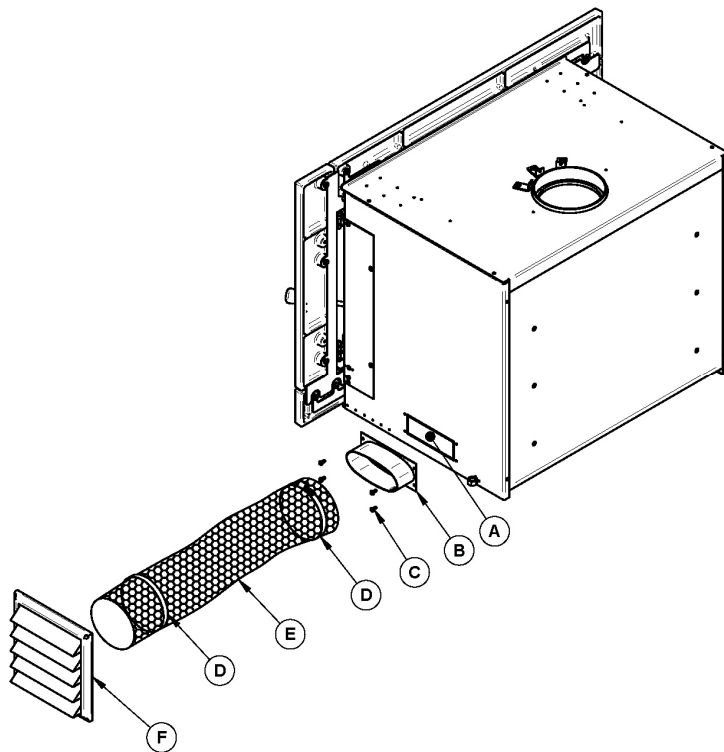

Then, install the fresh air kit adapter (B) using 4 screws (C). Secure the flexible pipe (E) (part #AC02090 not supplied) to the adapter (B) using one of the adjustable pipe clamps (D). Secure the other end of the pipe to the outside wall termination (F) using the second adjustable pipe clamp (D). The outside wall termination (F) must be installed outside of the building.

## APPENDIX 3: OPTIONAL FACEPLATE INSTALLATION

**NOTE:** If the depth and or the opening of the masonry hearth require the use of the projection kit AC01323 and or a faceplate backing plate kit AC01322 or AC01332, follow the instructions included with these options before beginning the installation of the cast iron faceplate. Note also that in order to install the optional projection kit AC01323, one of the optional faceplate backing plate kit AC01322 or AC01332 must be purchased separately to secure the projection kit to it.

Remove the faceplate parts of the packaging and inspect its content. Then remove the wing nut that secures the blower switch assembly to the floor of the convection air jacket for transport. The faceplate installation requires a ratchet and 3/8" box to secure each part to the front of the wood inbuilt.

The back of each faceplate part is identified as follow: (A) = 24249, (B) = 24250, (F) = 24248 and (G) = 24247.

1. Secure the blower switch assembly (D) to the faceplate (A) with 2 screws (E).
2. Align the holes in the support bracket of faceplate (A) with the screws (C) already installed on the wood inbuilt, and then tighten the screws. Use the same procedure for faceplate (B).

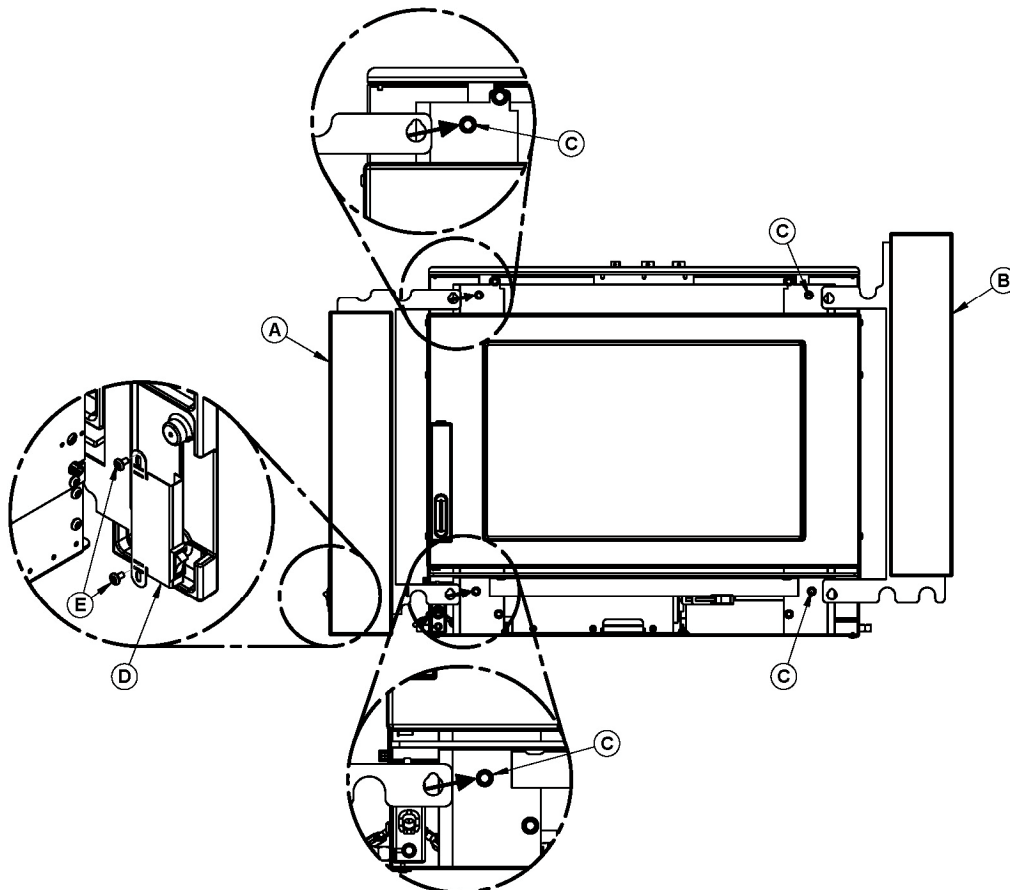

3. Align the holes in the support bracket of faceplate (F) then tighten the screws (H) already installed on the wood inbuilt.
4. Align the holes in the support bracket of faceplate (G) then tighten the screws (H) already installed on the wood inbuilt.

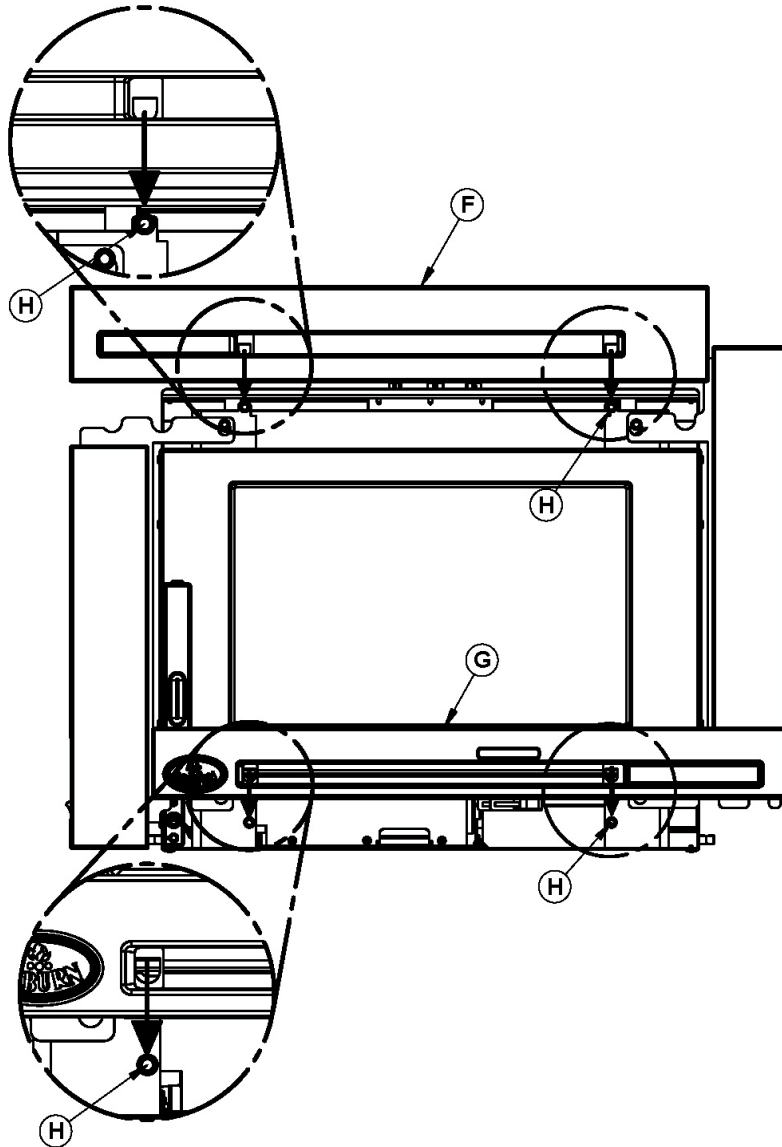

## APPENDIX 4: BLOWER INSTALLATION

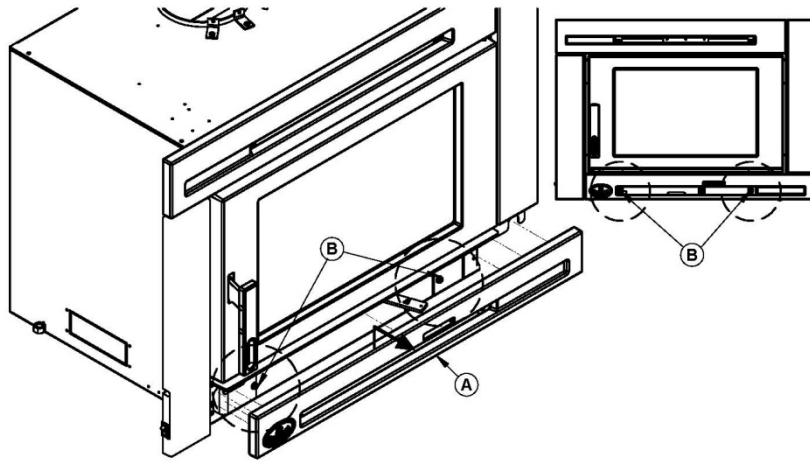

1. Slightly loosen screws (B).
2. Lift the faceplate (A) by 13 mm (1/2") then pull it towards you to remove.

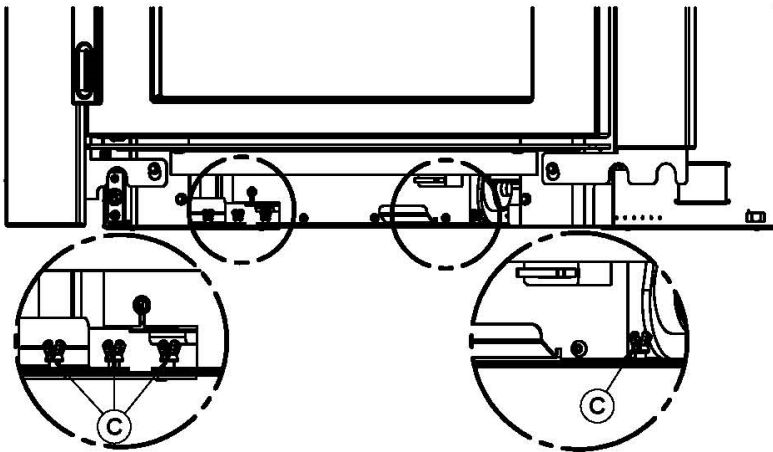

3. Slightly loosen the 4 wing nut (C) then pull the blower assembly (D) towards you to remove it from the convection air jacket. Make sure to disconnect the wiring as it is accessible.

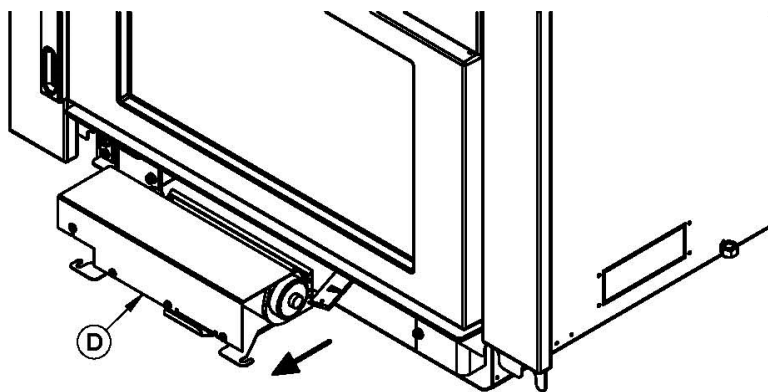

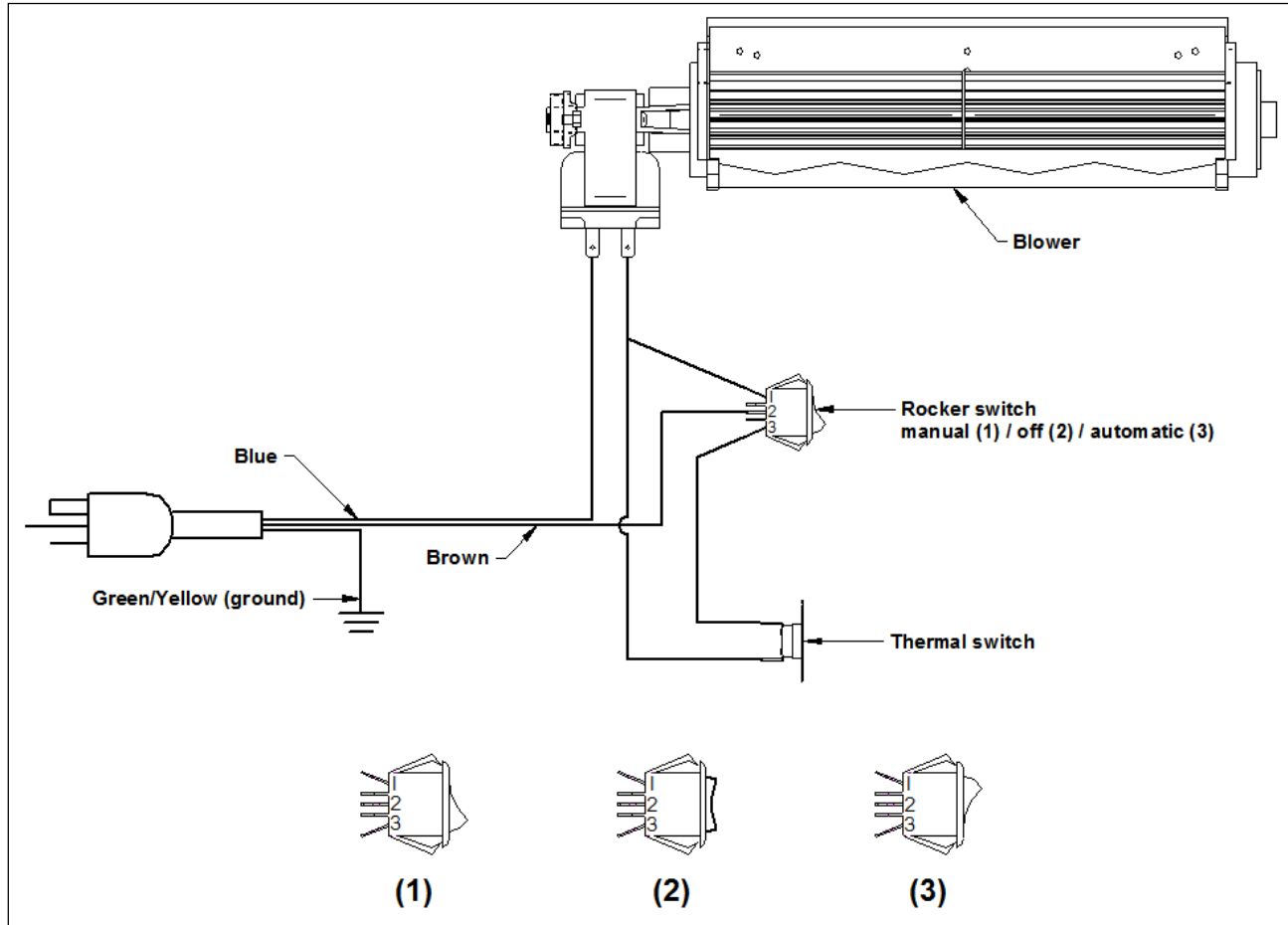

## APPENDIX 5: INSTALLING THE OPTIONAL FIRE SCREEN (AC01315)

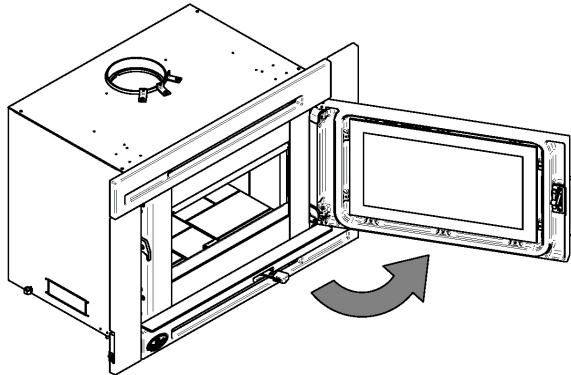

Open the door.

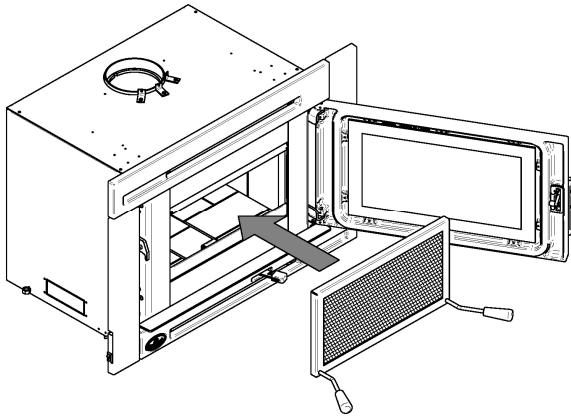

Hold the fire screen by the two handles and bring it close to the door opening.

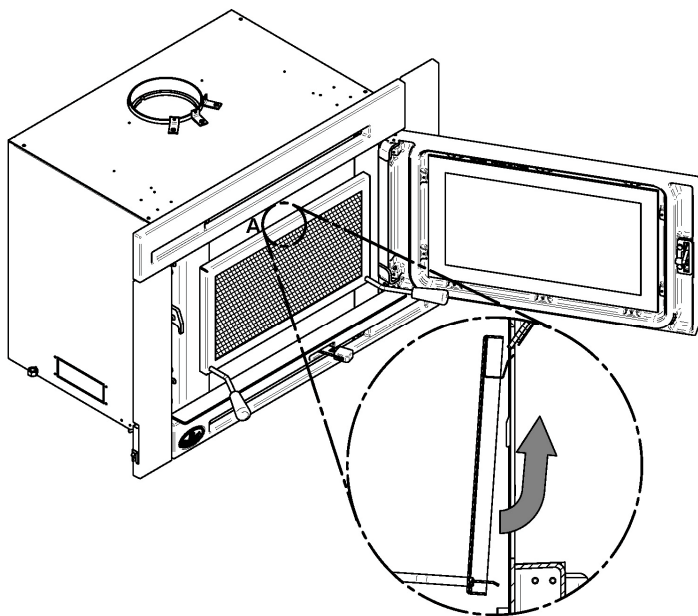

Lean the upper part of the fire screen against the top door opening making sure to insert the top fire screen brackets behind the primary air deflector as in **(DETAIL A)**.

Lift the fire screen upwards and push the bottom part towards the wood inbuilt then let the fire screen rest on the bottom of the door opening.

DETAIL A

**Warning:** Never leave the wood inbuilt unattended while in use with the fire screen.

## APPENDIX 6: INSTALLATION OF SECONDARY AIR TUBES AND BAFFLE

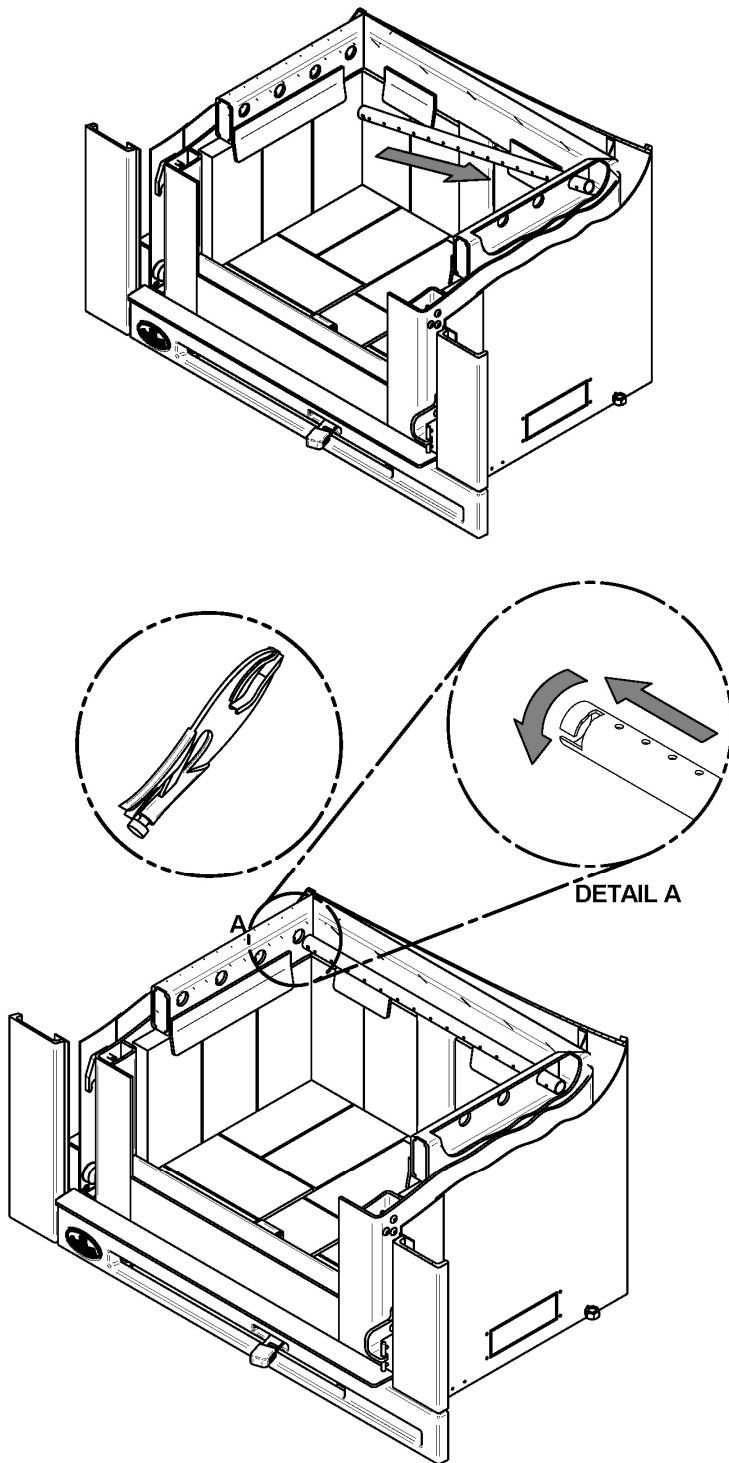

1. Starting with the rear tube, lean and insert the right end of the secondary air tube into the rear right channel hole. Then lift and insert the left end of the tube into the rear left channel.
2. Align the notch in the left end of the tube with the key of the left air channel hole. Using a « Wise grip » hold the tube and lock it in place by turning the tube as shown in **DETAIL A**. Make sure the notch reaches the end of the key way.
3. Repeat **steps 1** and **2** for the two tubes in the back then install the baffle before installing the two front tubes.
4. To remove the tubes use the above steps in reverse order.



**Note that** secondary air tubes (A) can be replaced without removing the baffle board (B).

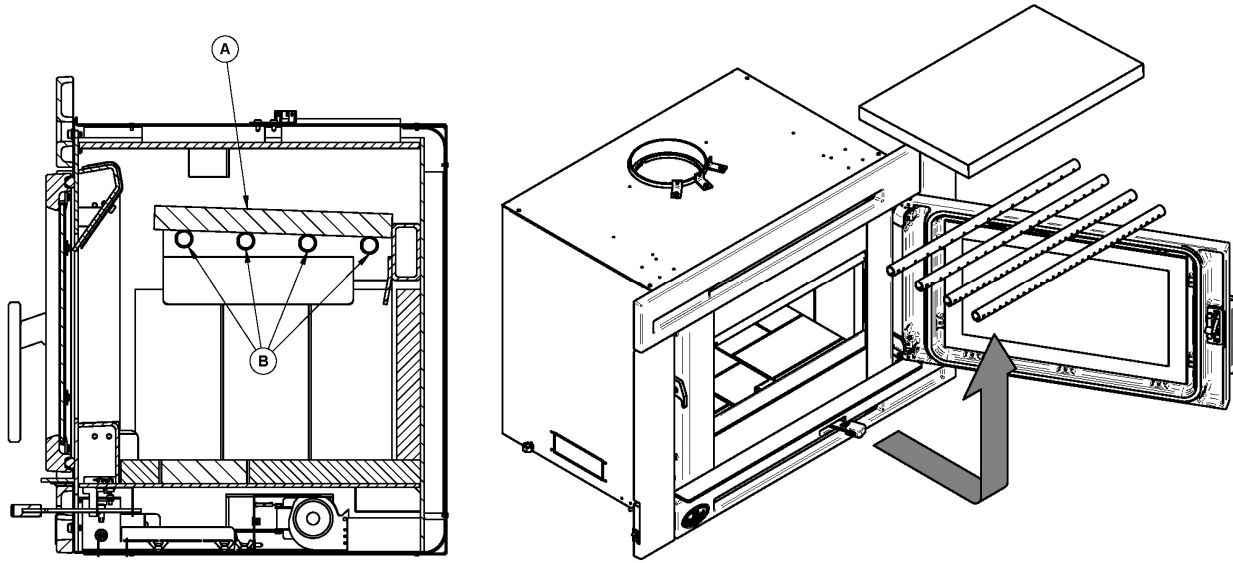

**Important Notes:**

The air tubes are identified for placement as follows:

<b>Model</b>	<b>Type of tube</b>
Matrix wood inbuilt	Front ► 30 holes of 3.75mm Middle front ► 30 holes of 3.5mm Middle rear ► 20 holes of 3.25mm Rear ► 15 holes of 3.25mm

## APPENDIX 7: REMOVAL INSTRUCTIONS

For the purpose of inspecting the wood inbuilt itself or the fireplace, your wood inbuilt may need to be removed. To remove your wood inbuilt follow these instructions:

- Remove the faceplate assembly (A) using the reverse steps of **Appendix 3**.
- If installed, take-off the backing plates (B) and (C) and the projection kit by removing the front screws securing them to the wood inbuilt.
- Remove the screws that secure the flue liner to the fixation brackets (E).
- Unscrew the leveling bolts (F) located on each side of the wood inbuilt.
- Pull-out the wood inbuilt from the fireplace opening to perform the maintenance work.

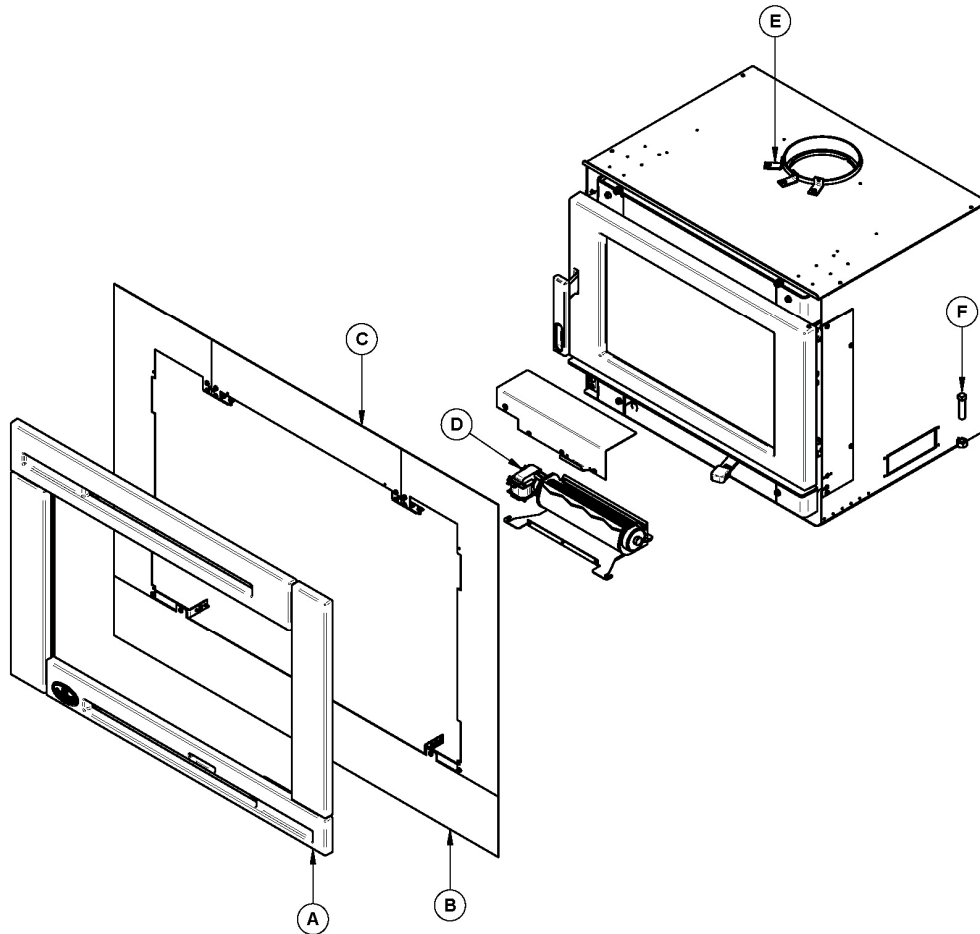

## APPENDIX 8: EXPLODED DIAGRAM AND PARTS LIST

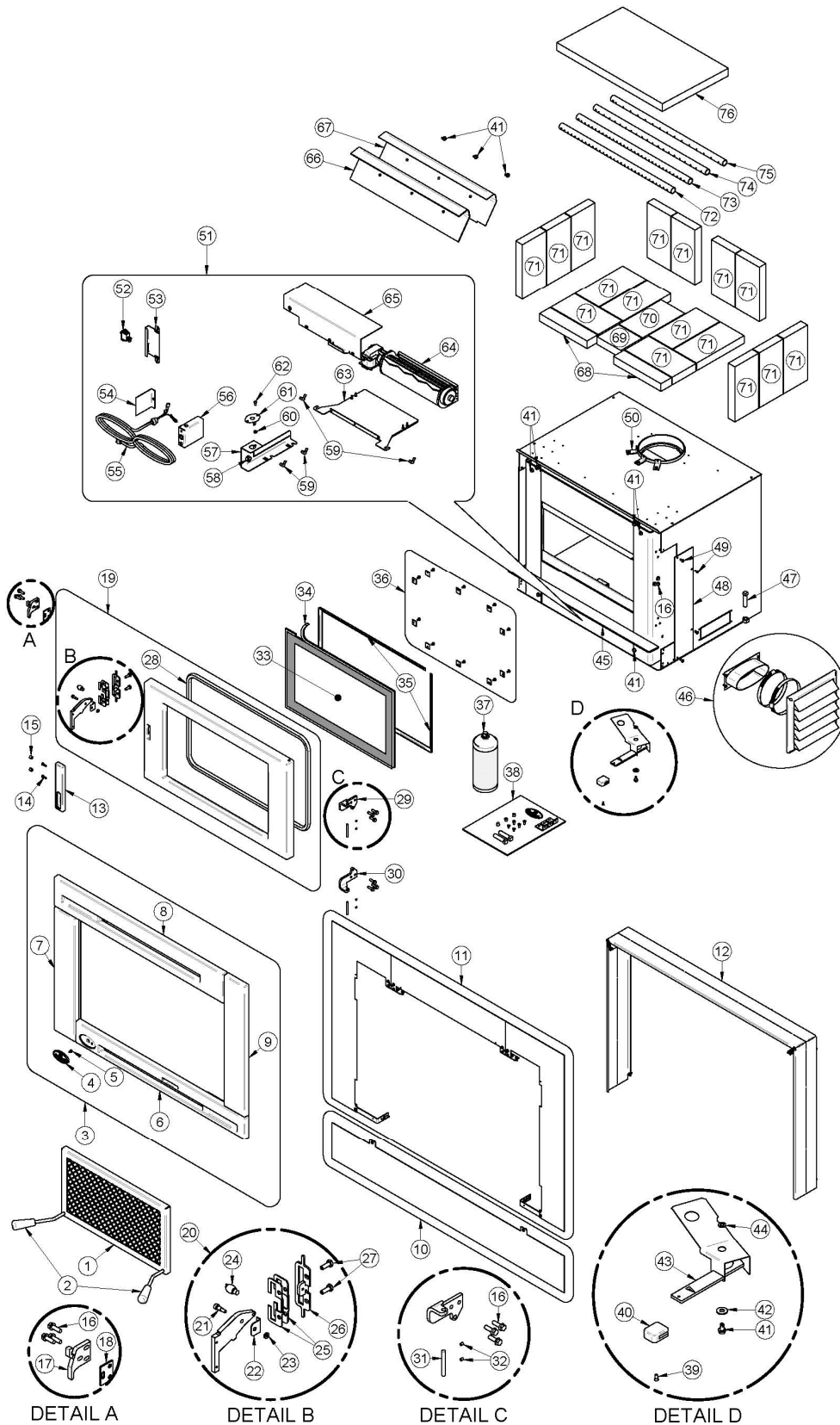

**IMPORTANT:** THIS IS DATED INFORMATION. When requesting service or replacement parts for your wood inbuilt, please provide the model number and the serial number. We reserve the right to change parts due to technology upgrade or availability. Contact an authorized dealer to obtain any of these parts. Never use substitute materials. Use of non-approved parts can result in poor performance and safety hazards.

#	Item	Description	Qty
1	AC01315	FIRE SCREEN	1
2	30569	ROUND WOODEN HANDLE BLACK	2
3	SE24247	FACEPLATE KIT FOR MATRIX WOOD INBUILT	1
4	30450	OSBURN DOOR LOGO	1
5	30124	SCREW #8 - 32 X 5/16" TRUSS QUADREX ZINC	1
6	24247	BOTTOM CAST IRON FACEPLATE	1
7	24249	LEFT CAST IRON FACEPLATE	1
8	24248	TOP CAST IRON FACEPLATE	1
9	24250	RIGHT CAST IRON FACEPLATE	1
10	AC01333	1270MM X 152MM BOTTOM FACEPLATE BACKING PLATE	1
10	AC01321	1118MM X 152MM BOTTOM FACEPLATE BACKING PLATE	1
11	AC01322	737MM X 1118MM FACEPLATE BACKING PLATE KIT	1
11	AC01332	737MM X 1270MM FACEPLATE BACKING PLATE KIT	1
12	AC01323	PROJECTION KIT FOR WOOD INBUILT – 51MM OR 102MM	1
13	30765	WOODEN DOOR HANDLE	1
14	30123	SCREW #8 - 32 X 5/8" PAN QUADREX ZINC	2
15	30766	WOODEN CAP HANDLE	2
16	30506	SCREW PAN TORX TYPE F 1/4-20 X 1" BLACK	12
17	PL65621	DOOR LATCH	1
18	PL64696	SPACER	3
19	SE24245	CAST IRON DOOR WITH GASKET AND HANDLE	1
20	AC09154	HANDLE MECHANISM	1
21	30754	HEX SOCKET SHOULDER HEX SCREW #10-24 X 3/8"	1
22	PL65695	HANDLE MECHANISM SPACER	1
23	30359	HEX NUT #10-24 ZINC	1
24	AC09168	DOOR LATCH KIT MATRIX	1
25	PL65622	LATCH SPACER	2
26	SE65742	DOOR LATCH ASSEMBLY	1
27	30093	BOLT 1/4-20 X 3/4" HEX GRADE 5	2
28	AC06500	SILICONE AND 16MM X 2.4M BLACK GASKET KIT	1
29	PL65614	DOOR HINGE	1
30	PL65615	DOOR HINGE	1
31	30755	DOWEL PIN 1/4" x 2"	2
32	30117	SOCKET SET SCREW #10-32 X 1/4"	4
33	23051	MATRIX ROBAX GLASS	1
34	AC06400	BLACK SELF-ADHESIVE GLASS GASKET KIT (1.8M)	1

#	Item	Description	Qty
35	PL65646	GLASS FRAME	2
36	SE63024	GLASS RETAINER WITH SCREWS KIT (10 PER KIT)	10
37	AC05959	METALLIC BLACK STOVE PAINT - 342 g (12oz) AEROSOL	10
38	SE45642	INSTRUCTION MANUEL KIT MATRIX WOOD INBUILT	1
39	30075	BRASS METAL SCREW #6 X 1/2" QUADREX	1
40	30764	WOODEN AIR CONTROL HANDLE	1
41	30060	THREAD-CUTTING SCREW 1/4-20 x 1/2" F HEX STEEL SLOT WASHER C102 ZINC	1
42	30206	ZINC WASHER ID=5/16" x OD=3/4"	1
43	SE65767	AIR CONTROL DAMPER ASSEMBLY	1
44	30187	ZINC WASHER ID 17/64" x OD 1/2"	1
45	SE65754	ASH LIP	1
46	AC01298	FRESH AIR INTAKE KIT – 127MM DIAMETER	1
47	30337	SQUARE HEAD SET SCREW 1/2-13 X 1-3/4"	2
48	PL65731	LATCH AND HINGES ACCESS PANEL	2
49	30131	BLACK METAL SCREW #10 X 1/2" TYPE "A" PAN QUADREX	8
50	PL34052	LINER FIXATION BRACKET	3
51	SE65746-01	BLOWER ASSEMBLY	1
52	44092	ROCKER SWITCH 3 POSITION MSR-8	1
53	PL65752	SWITCH BRACKET	1
54	PL65629	JUNCTION BOX COVER	1
55	60020	POWER CORD 2.4M X 18-3	1
56	PL65627	JUNCTION BOX	1
57	PL65626	BLOWER WIRE GUIDE	1
58	30413	SNAP BUSHING	1
59	30484	WING NUT 1/4-20	4
60	30417	BLACK HEX NUT #8-32	1
61	44028	CERAMIC THERMODISC F110-20F	1
62	30239	MECHANICAL SCREW #8 - 32 x 3/8" QUADREX ZINC	1
63	PL65746	BLOWER BOTTOM FIXATION PLATE	1
64	44074	BLOWER STOVES (50 HZ)	1
65	PL65748	BLOWER PROTECTION COVER	1
66	21387	TOP AIR DEFLECTOR INSULATION	1
67	PL65505	TOP AIR DEFLECTOR PROTECTOR	1
68	PL36021	REFRACTORY BRICK HD 32MM X 54MM X 229MM	2
69	VP00020	REFRACTORY BRICK HD 32MM X 102MM X 114MM	1
70	PL36028	REFRACTORY BRICK HD 32MM X 114MM X 206MM	1
71	29011	REFRACTORY BRICK HD 32MM X 102MM X 229MM	16
72	PL65514	FRONT SECONDARY AIR TUBE	1
73	PL65515	MIDDLE FRONT SECONDARY AIR TUBE	1
74	PL65516	MIDDLE REAR SECONDARY AIR TUBE	1
75	PL65517	REAR SECONDARY AIR TUBE	1
76	21389	C-CAST BAFFLE 32MM X 508MM X 318MM	1

Manufactured by:

**STOVE BUILDER INTERNATIONAL INC.**

250, de Copenhague, Saint-Augustin-de-Desmaures (Quebec), Canada G3A 2H3

After-sale service: 418-908-8002 E-mail: tech@sbi-international.com

[www.osburn-australia.com](http://www.osburn-australia.com)

Distributed by:

My Fireplace Australia PTY Ltd